



An Oshkosh Corporation Company

Operation and Safety Manual

Original Instructions - Keep this manual with the machine at all times.

Model(s)

15/20MVL

15/20MSP

ANSI



P/N - 3121230

December 20, 2013

FOREWORD

This manual is a very important tool! Keep it with the machine at all times.

The purpose of this manual is to provide owners, users, operators, lessors, and lessees with the precautions and operating procedures essential for the safe and proper machine operation for its intended purpose.

Due to continuous product improvements, JLG Industries, Inc. reserves the right to make specification changes without prior notification. Contact JLG Industries, Inc. for updated information.

Other Publications Available:

Service Manual 3121231
Illustrated Parts Manual. 3121232

SAFETY ALERT SYMBOLS AND SAFETY SIGNAL WORDS



This is the Safety Alert Symbol. It is used to alert you to the potential personal injury hazards. Obey all safety messages that follow this symbol to avoid possible injury or death

⚠ DANGER

INDICATES AN IMMINENTLY HAZARDOUS SITUATION. IF NOT AVOIDED, WILL RESULT IN SERIOUS INJURY OR DEATH. THIS DECAL WILL HAVE A RED BACKGROUND.

⚠ WARNING

INDICATES A POTENTIALITY HAZARDOUS SITUATION. IF NOT AVOIDED, COULD RESULT IN SERIOUS INJURY OR DEATH. THIS DECAL WILL HAVE AN ORANGE BACKGROUND.

⚠ CAUTION

INDICATES A POTENTIALITY HAZARDOUS SITUATION. IF NOT AVOIDED, MAY RESULT IN MINOR OR MODERATE INJURY. IT MAY ALSO ALERT AGAINST UNSAFE PRACTICES. THIS DECAL WILL HAVE A YELLOW BACKGROUND.

NOTICE

INDICATES INFORMATION OR A COMPANY POLICY THAT RELATES DIRECTLY OR INDIRECTLY TO THE SAFETY OF PERSONNEL OR PROTECTION OF PROPERTY.

⚠ WARNING

THIS PRODUCT MUST COMPLY WITH ALL SAFETY RELATED BULLETINS. CONTACT JLG INDUSTRIES, INC. OR THE LOCAL AUTHORIZED JLG REPRESENTATIVE FOR INFORMATION REGARDING SAFETY RELATED BULLETINS WHICH MAY HAVE BEEN ISSUED FOR THIS PRODUCT.

NOTICE

JLG INDUSTRIES, INC. SENDS SAFETY RELATED BULLETINS TO THE OWNER OF RECORD OF THIS MACHINE. CONTACT JLG INDUSTRIES, INC. TO ENSURE THAT THE CURRENT OWNER RECORDS ARE UPDATED AND ACCURATE.

NOTICE

JLG INDUSTRIES, INC. MUST BE NOTIFIED IMMEDIATELY IN ALL INSTANCES WHERE JLG PRODUCTS HAVE BEEN INVOLVED IN AN ACCIDENT INVOLVING BODILY INJURY OR DEATH OF PERSONNEL OR WHEN SUBSTANTIAL DAMAGE HAS OCCURRED TO PERSONAL PROPERTY OR THE JLG PRODUCT.

For :

- Accident Reporting
- Product Safety Publications
- Current Owner Updates
- Questions Regarding Product Safety
- Standards and Regulations Compliance Information
- Questions Regarding Special Product Applications
- Questions Regarding Product Modifications

Contact :

Product Safety and Reliability Department
JLG Industries, Inc.
13224 Fountainhead Plaza
Hagerstown, MD 21742

or Your Local JLG Office
(See addresses on inside of manual cover)

In USA:

Toll Free: 877-JLG-SAFE (877-554-7233)

Outside USA:

Phone: 240-420-2661
E-mail: ProductSafety@JLG.com

REVISION LOG

Original Issue of Manual November 29, 2005
Manual Revised April 19, 2006
Manual Revised October 4, 2006
Manual Revised April 2, 2007
Manual Revised November 6, 2007
Manual Revised May 12, 2009
Manual Revised December 22, 2009
Manual Revised November 24, 2010
Manual Revised February 24, 2012
Manual Revised December 5, 2013
Manual Revised December 20, 2013

TABLE OF CONTENTS

SECTION - PARAGRAPH, SUBJECT	PAGE
FOREWORD	A
SAFETY ALERT SYMBOLS AND SAFETY SIGNAL WORDS	B
Contact :	C
In USA:	C
Outside USA:	C
REVISION LOG	D
SECTION - 1 - SAFETY PRECAUTIONS	
1.1 GENERAL	1-1
1.2 PRE-OPERATION	1-1
Operator Training And Knowledge	1-1
Workplace Inspection	1-2
Machine Inspection	1-2
1.3 OPERATION	1-3
General	1-3
Trip and Fall Hazard	1-3
Electrocution Hazards	1-4
Tipping Hazard	1-6
Crushing And Collision Hazard	1-7
1.4 TOWING, LIFTING, AND HAULING	1-8

SECTION - PARAGRAPH, SUBJECT	PAGE
SECTION - 2 - PREPARATION AND INSPECTION	
2.1 PERSONNEL TRAINING	2-1
Operator Training	2-1
Training Supervision	2-2
Operator Responsibility	2-2
2.2 PREPARATION, INSPECTION, AND MAINTENANCE	2-2
2.3 PRE-START INSPECTION	2-4
2.4 DAILY WALK-AROUND INSPECTION	2-5
2.5 FUNCTION CHECK	2-7
SECTION - 3 - MACHINE CONTROLS, INDICATORS AND OPERATION	
3.1 GENERAL	3-1
3.2 MACHINE DESCRIPTION	3-1
3.3 MACHINE OPERATION	3-2
Getting Started	3-2
3.4 BATTERY CHARGING	3-2
Battery - Low Voltage Warning Indicators	3-3
To Charge Batteries	3-4
Battery Charging Status Indicators	3-4
3.5 GROUND CONTROL STATION - OPERATION	3-7
Main Power Selector Switch	3-7
Emergency Stop/Shut Down Button	3-7

TABLE OF CONTENTS

SECTION - PARAGRAPH, SUBJECT	PAGE
Brake Release Button	3-7
Platform Up	3-9
Platform Down	3-9
Manual Descent Control Valve	3-9
Machine Status LCD Display	3-10
LCD Display Fault Conditions	3-11
3.6 PLATFORM CONTROL CONSOLE OPERATION	3-15
General	3-16
Platform On/Off Key Switch	3-16
Platform Emergency Stop Button	3-17
Platform Control Display Panel	3-17
Drive/Lift Mode Selector Switch	3-19
Horn Button	3-19
Joystick Function Enable Lever	3-19
Multifunction Joystick Control	3-20
Drive Mode	3-20
Lift Mode	3-22
Drive Speed Setting Controls	3-23
3.7 PARKING MACHINE	3-24
3.8 PLATFORM CONFIGURATIONS	3-24
StockPicking Platform Operation	3-28
3.9 FALL PROTECTION - LANYARD ATTACHMENT	3-30
3.10 QUICK-CHANGE PLATFORM MOUNTING	3-31
Platform Removal (see illustration following)	3-31

SECTION - PARAGRAPH, SUBJECT	PAGE
Platform Installation	3-31
3.11 TRANSPORTING, LIFTING AND TIE DOWN PROCEDURES	3-32
General	3-32
Truck Transport	3-32
Machine Tie-Down	3-33
Crane Hook Accessory (Option)	3-33
Fork-Lift Truck Transport	3-34
3.12 PROGRAMMABLE SECURITY LOCK (PSL™) (MVL/MSP - OPTION)	3-36
PSL™ Box and Ground Control Locations	3-36
Machine Power Up using the PSL™	3-37
Machine Power Down	3-37
Changing the Operator's Code	3-37
3.13 OBSTRUCTION SENSING SYSTEM - (MSP OPTION)	3-38
System Description	3-38
Operation	3-38
OSS Pre-Start Inspection	3-39
3.14 RUG CARRIER ACCESSORY (MSP - OPTION)	3-41
General	3-41
Pre-Start Inspection	3-41

TABLE OF CONTENTS

SECTION - PARAGRAPH, SUBJECT	PAGE
Hanging a Rug using the Rug Carrier	
Accessory Arms	3-41
Removing a Rug using Rug Carrier	
Accessory Arms	3-43
3.15 STOCK-PICKER HANGER ACCESSORY	3-45
Pre-Start Inspection	3-45
Loading and Transporting an Item using the Hanger Accessory	3-45
SECTION - 4 - EMERGENCY PROCEDURES	
4.1 GENERAL INFORMATION	4-1
4.2 EMERGENCY OPERATION	4-1
Operator Unable to Control Machine	4-1
Platform Caught Overhead	4-1
4.3 INCIDENT NOTIFICATION	4-1
SECTION - 5 - GENERAL SPECIFICATIONS AND OPERATOR MAINTENANCE	
5.1 INTRODUCTION	5-1
5.2 GENERAL SPECIFICATIONS	5-2
Machine Specifications	5-2
Machine Wheel Loads and PSI - Per Wheel	5-4
Electrical Specifications	5-6

SECTION - PARAGRAPH, SUBJECT	PAGE
Platform Data	5-7
Machine Component Weights	5-8
Serial Number Locations	5-8
5.3 OPERATOR MAINTENANCE	5-9
Battery	5-9
Tires and Wheels	5-9
Lubrication	5-11
5.4 GROUND CONTROL STATION - PROGRAMMING5-14	
General	5-14
Programming Levels	5-14
Operator Programming Mode	5-14
Activating Programming Mode	5-17
Entering Password	5-18
Programming Mode Selection	5-18
Selecting Programmable Item to Adjust	5-19
Adjusting Programmable Setting	5-19
5.5 DRIVE MOTOR BRUSH WEAR - WARNING INDICATION	5-20
5.6 SUPPLEMENTAL INFORMATION	5-21

SECTION - 6 - INSPECTION AND REPAIR LOG

TABLE OF CONTENTS

SECTION - PARAGRAPH, SUBJECT	PAGE
LIST OF FIGURES	
2-1. Daily Walk-Around Inspection for MVL/MSP Machines.	2-6
2-2. Pot-Hole-Protection Bars Lowered.	2-7
3-1. Ground Control Station. (Machine Rear View).	3-8
3-2. Platform Control Console.	3-15
3-3. Platform Control Display Panel.	3-17
3-4. Machine Operating Specifications.	3-21
3-5. Crane Hook Accessory	3-33
3-6. Forklift Truck Lifting Pockets and Machine Tie Down Loop Locations	3-35
3-7. PSL™ Switch & Ground Control Station Locations - At Rear of Machine	3-36
3-8. PSL™ Switch Controls & Indicators.	3-36
3-9. OSS Transducer Sensor Array Location.	3-39
3-10. OSS - Pre-Start Inspection of Operation.	3-40
3-11. MVL Series Decal Installation Chart - (See Table 3-4 for Installation)	3-47
3-12. MSP Decal Installation Chart - (See Table 3-5. for Installation)	3-50
5-1. Wheel Lug Nut Tightening Sequence	5-10
5-2. Location of Lubrication Points (See Table 5-5)	5-12

SECTION - PARAGRAPH, SUBJECT	PAGE
LIST OF TABLES	
Minimum Approach Distances (M.A.D.)	1-5
Inspection and Maintenance Table	2-3
Battery Low Voltage Warning Indicators.	3-3
LCD Display - Operation Fault Conditions.	3-12
Max. Capacity with Side Entry Platform w/Folding Material Tray Installed	3-26
MVL Series Decal Installation Chart.	3-48
MSP Decal Installation Chart.	3-51
15MVL/MSP - Machine Maximum Wheel Loads (Lb.) and (PSI) - Per Wheel.	5-4
20MVL/MSP - Machine Maximum Wheel Loads (Lb.) and (PSI) - Per Wheel.	5-5
Wheel Torque Chart.	5-10
Lubrication Specifications	5-11
Lubrication Intervals for Various Components	5-13
Ground Control Module Setting Range and Default Factory Settings.	5-16
Inspection and Repair Log.	6-1

SECTION 1. SAFETY PRECAUTIONS

1.1 GENERAL

This section outlines the necessary precautions for proper and safe machine usage and maintenance. For proper machine use, it is mandatory that a daily routine is established based on the content of this manual. A maintenance program, using the information provided in this manual and the Service and Maintenance Manual, must also be established by a qualified person and must be followed to ensure that the machine is safe to operate.

The owner/user/operator/lessor/lessee of the machine should not accept operating responsibility until this manual has been read, training is accomplished, and operation of the machine has been completed under the supervision of an experienced and qualified operator.

If there are any questions with regard to safety, training, inspection, maintenance, application, and operation, please contact JLG Industries, Inc. (“JLG”).

WARNING

FAILURE TO COMPLY WITH THE SAFETY PRECAUTIONS LISTED IN THIS MANUAL COULD RESULT IN MACHINE DAMAGE, PROPERTY DAMAGE, PERSONAL INJURY OR DEATH.

1.2 PRE-OPERATION

Operator Training And Knowledge

- Read and understand this manual before operating the machine.

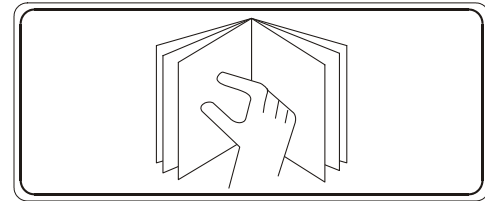

- Do not operate this machine until complete training is performed by authorized persons.
- Only authorized and qualified personnel can operate the machine.
- Read, understand, and obey all DANGERS, WARNINGS, CAUTIONS, and operating instructions on the machine and in this manual.
- Use the machine in a manner which is within the scope of its intended application set by JLG.

SECTION 1 - SAFETY PRECAUTIONS

- All operating personnel must be familiar with the emergency controls and emergency operation of the machine as specified in this manual.
- Read, understand, and obey all applicable employer, local, and governmental regulations as they pertain to operation of the machine.

Workplace Inspection

- The operator is to take safety measures to avoid all hazards in the work area prior to machine operation.
- Do not operate or raise the platform while on trucks, trailers, railway cars, floating vessels, scaffolds or other equipment unless approved in writing by JLG.
- This machine can be operated in temperatures of 0° F to 104° F (-20° C to 40° C). Consult JLG for operation outside this range.

Machine Inspection

- Before machine operation, perform inspections and functional checks. Refer to Section 2 of this manual for detailed instructions.
- Do not operate this machine until it has been serviced and maintained according to requirements specified in the Service and Maintenance Manual.
- Ensure all safety devices are operating properly. Modification of these devices is a safety violation.

WARNING

MODIFICATION OR ALTERATION OF AN AERIAL WORK PLATFORM SHALL BE MADE ONLY WITH PRIOR WRITTEN PERMISSION FROM THE MANUFACTURER

- Do not operate any machine on which the safety or instruction placards or decals are missing or illegible.
- Avoid any build up of debris on platform floor. Keep mud, oil, grease, and other slippery substances from footwear and platform floor.

1.3 OPERATION

General

- Do not use the machine for any purpose other than positioning personnel, their tools and equipment, or for hand stock picking.
 - Never operate a machine that is not working properly. If a malfunction occurs, shut down the machine.
 - Never slam a control switch or lever through neutral to an opposite direction. Always return switch to neutral and stop before moving the switch to the next function. Operate controls with slow and even pressure.
 - Do not allow personnel to tamper with or operate the machine from the ground with personnel in the platform, except in an emergency.
 - Do not carry materials directly on platform railing unless approved by JLG.
 - Always ensure that power tools are properly stowed and never left hanging by their cord from the platform work area.
 - Fully lower mast assembly and shut off all power before leaving machine.
- When performing welding operations at elevation, precautions must be taken to protect all machine components from contact with weld splatter or molten metal.
 - Battery fluid is highly corrosive. Avoid contact with skin and clothing at all times.
 - Charge batteries on in a well ventilated area.

Trip and Fall Hazard

- JLG Industries, Inc. recommends that the operator in the platform wear approved fall protection attached to an authorized lanyard anchorage point. Reference “Stock-Picking Platform Operation” on page 28 for fall protection requirements applicable to stockpicker platforms operated with the rails in the open position. For further information regarding fall protection requirements on JLG products, contact JLG Industries, Inc.

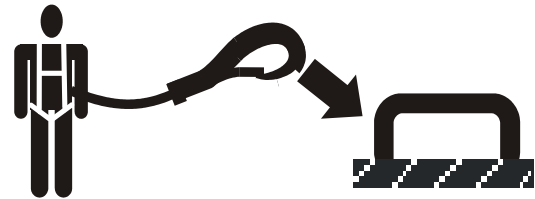

SECTION 1 - SAFETY PRECAUTIONS

- Before operating the machine, make sure all railing and gates are fastened in their proper position.



- Keep both feet firmly positioned on the platform floor at all times. Never use ladders, boxes, steps, planks, or similar items on platform to provide additional reach.
- Never use the mast assembly to enter or leave the platform.
- Use extreme caution when entering or leaving platform. Ensure that the mast assembly is fully lowered. Face the machine when entering or leaving the platform. Always maintain “three point contact” with the machine, using two hands and one foot or two feet and one hand at all times during entry and exit.

Electrocution Hazards

- This machine is not insulated and does not provide protection from contact or proximity to electrical current.

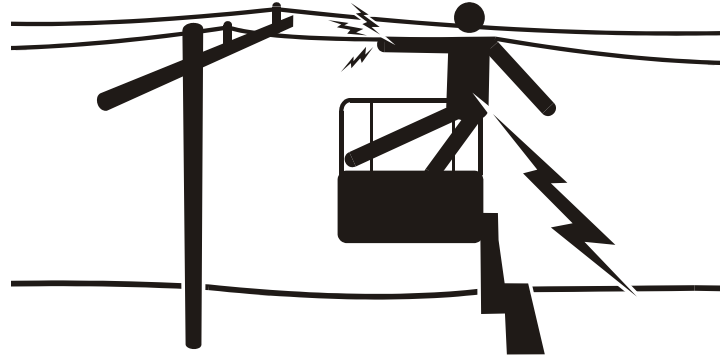

- Maintain distance from electrical lines, apparatus, or any energized (exposed or insulated) parts according to the Minimum Approach Distance (MAD) as shown in Table 1-1.
- Allow for machine movement and electrical line swaying.

Table 1-1. Minimum Approach Distances (M.A.D.)

Voltage Range (Phase to Phase)	MINIMUM APPROACH DISTANCE in Feet (Meters)
0 to 50 KV	10 (3)
Over 50KV to 200 KV	15 (5)
Over 200 KV to 350 KV	20 (6)
Over 350 KV to 500 KV	25 (8)
Over 500 KV to 750 KV	35 (11)
Over 750 KV to 1000 KV	45 (14)
<i>NOTE: This requirement shall apply except where employer, local or governmental regulations are more stringent.</i>	

- Maintain a clearance of at least 10 ft. (3m) between any part of the machine and its occupants, their tools, and their equipment from any electrical line or apparatus carrying up to 50,000 volts. One foot additional clearance is required for every additional 30,000 volts or less.
- The minimum approach distance may be reduced if insulating barriers are installed to prevent contact, and the barriers are rated for the voltage of the line being guarded. These barriers shall not be part of (or attached to) the machine. The minimum approach distance shall be reduced to a distance within the designed working dimensions of the insulating barrier. This determination shall be

made by a qualified person in accordance with the employer, local, or governmental requirements for work practices near energized equipment



DO NOT MANEUVER MACHINE OR PERSONNEL INSIDE PROHIBITED ZONE (MAD). ASSUME ALL ELECTRICAL PARTS AND WIRING ARE ENERGIZED UNLESS KNOWN OTHERWISE.

SECTION 1 - SAFETY PRECAUTIONS

Tipping Hazard

- The user should be familiar with the surface before driving. Do not exceed the allowable sideslope and grade while driving.

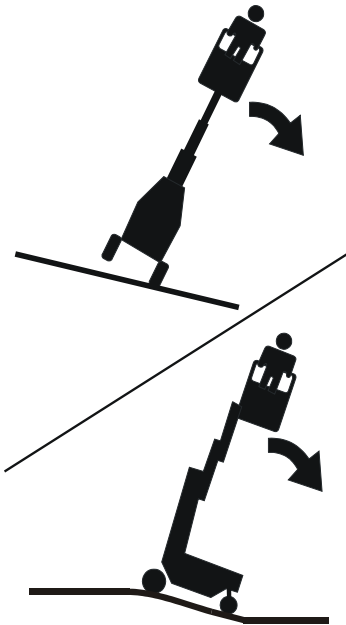

- Do not elevate platform or drive with platform elevated while on a slope, or on an uneven or soft surface.
- Before driving on floors, bridges, trucks, and other surfaces, check allowable capacity of the surfaces.
- Never exceed the maximum platform capacity. Distribute loads evenly on platform floor.
- Keep the chassis of the machine a minimum of 2 ft. (0.6m) from holes, bumps, drop-offs, obstructions, debris, concealed holes, and other potential hazards at the ground level.
- Never attempt to use the machine as a crane. Do not tie-off machine to any adjacent structure.
- Do not increase the platform size with unauthorized deck extensions or attachments, increasing the area exposed to wind will decrease stability.
- If mast assembly or platform is caught so that one or more wheels are off the ground, the operator must be removed before attempting to free the machine. Use cranes, forklift trucks, or other appropriate equipment to stabilize machine and remove personnel.

Crushing And Collision Hazard

- Personal protection equipment must be worn by all operating and ground personnel.
- Check work area clearances above, on sides, and bottom of platform while driving and lifting or lowering platform.



- During operation, keep all body parts inside platform railing.
- Always post a lookout when driving in areas where vision is obstructed.

- Keep non-operating personnel at least 6 ft. (1.8m) away from machine during all driving operations.
- Limit travel speed according to conditions of ground surface, congestion, visibility, slope, location of personnel, and other factors causing hazards of collision or injury to personnel.
- Be aware of stopping distances in all drive speeds.
- Do not drive at high speeds in restricted or close quarters or when driving in reverse.
- Exercise extreme caution at all times to prevent obstacles from striking or interfering with operating controls and persons in the platform.
- Ensure that operators of other overhead and floor level machines are aware of the aerial work platform's presence. Disconnect power to overhead cranes.
- Warn personnel not to work, stand, or walk under a raised platform. Position barricades on floor as necessary.

SECTION 1 - SAFETY PRECAUTIONS

1.4 Towing, Lifting, And Hauling

- Never allow personnel in platform while towing, lifting, or hauling.
 - This machine should not be towed, except in the event of emergency, malfunction, power failure, or loading/unloading. Refer to the Emergency Procedures Section of this manual for emergency towing procedures.
 - Ensure platform is fully retracted and completely empty of tools prior to towing, lifting or hauling.
- Do not assist a stuck or disabled machine by pushing or pulling except by pulling at the chassis tie-down bars.
 - When lifting machine with a forklift, position forks only at designated areas of the machine. Lift with a forklift of adequate capacity.
 - Refer to the Machine Operation section of this manual for lifting information.

SECTION 2. PREPARATION AND INSPECTION

2.1 PERSONNEL TRAINING

The aerial platform is a personnel handling device; so it is necessary that it be operated and maintained only by trained personnel.

Persons under the influence of drugs or alcohol or who are subject to seizures, dizziness or loss of physical control must not operate this machine.

Operator Training

Operator training must cover:

1. Use and limitations of the controls in the platform and at the ground, emergency controls and safety systems.
2. Control labels, instructions, and warnings on the machine.
3. Rules of the employer and government regulations.
4. Use of approved fall protection device.
5. Enough knowledge of the mechanical operation of the machine to recognize a malfunction.
6. The safest means to operate the machine where overhead obstructions, other moving equipment, and obstacles, depressions, holes, drop-offs are present.
7. Means to avoid the hazards of unprotected electrical conductors.
8. Specific job requirements or machine application.

SECTION 2 - PREPARATION AND INSPECTION

Training Supervision

Training must be done under the supervision of a qualified person in an open area free of obstructions until the trainee has developed the ability to safely control and operate the machine.

Operator Responsibility

The operator must be instructed that he/she has the responsibility and authority to shut down the machine in case of a malfunction or other unsafe condition of either the machine or the job site.

NOTE: *The Manufacturer or Distributor will provide qualified people for training assistance with the first unit(s) delivered and from that time forward as requested by the user or his/her personnel.*

2.2 PREPARATION, INSPECTION, AND MAINTENANCE

The following table covers the periodic machine inspections and maintenance recommended by JLG Industries, Inc. Consult local regulations for further requirements for aerial work platforms. The frequency of inspections and maintenance must be increased as necessary when the machine is used in a harsh or hostile environment, if the machine is used with increased frequency, or if the machine is used in a severe manner.

SECTION 2 - PREPARATION AND INSPECTION

Table 2-1. Inspection and Maintenance Table

TYPE	FREQUENCY	PRIMARY RESPONSIBILITY	SERVICE QUALIFICATION	REFERENCE
Pre-Start Inspection	Before using each day; or whenever there's an Operator change.	User or Operator	User or Operator	Operator and Safety Manual
Pre-Delivery Inspection <i>(See Note)</i>	Before each sale, lease, or rental delivery.	Owner, Dealer, or User	Qualified JLG Mechanic	Service and Maintenance Manual and applicable JLG inspection form
Frequent Inspection	In service for 3 months or 150 hours, whichever comes first; or; Out of service for a period of more than 3 months; or Purchased used.	Owner, Dealer, or User	Qualified JLG Mechanic	Service and Maintenance Manual and applicable JLG inspection form
Annual Machine Inspection	Annually, no later than 13 months from the date of prior inspection.	Owner, Dealer, or User	Qualified JLG Mechanic <i>(Recommended)</i>	Service and Maintenance Manual and applicable JLG inspection form
Preventative Maintenance	At intervals as specified in the Service and Maintenance Manual.	Owner, Dealer, or User	Qualified JLG Mechanic	Service and Maintenance Manual

NOTE: *Inspection forms are available from JLG. Use the Service and Maintenance Manual to perform inspections.*

NOTICE

JLG INDUSTRIES, INC. RECOGNIZES A QUALIFIED JLG MECHANIC AS A PERSON WHO HAS SUCCESSFULLY COMPLETED THE JLG SERVICE TRAINING SCHOOL FOR THE SPECIFIC JLG PRODUCT MODEL.

SECTION 2 - PREPARATION AND INSPECTION

2.3 PRE-START INSPECTION

The Pre-Start Inspection should include each of the following:

1. **Cleanliness** – Check all surfaces for leakage (oil, fuel, or battery fluid) or foreign objects. Report any leakage to the proper maintenance personnel.
2. **Decals and Placards** – Check all for cleanliness and legibility. Make sure no decals or placards are missing. Make sure all illegible decals and placards are cleaned or replaced. (*Reference "Decal Installations" in Section 3*).
3. **Operators and Safety Manuals** – Make sure a copy of the Operator and Safety Manual, EMI Safety Manual (Domestic only), and ANSI Manual of Responsibilities (Domestic only) is enclosed in the weather resistant storage container.
4. **Daily Walk-Around Inspection** – (*See Section 2.4*)
5. **Battery** – Charge as required.

6. **Hydraulic Oil** – Check the hydraulic oil level.

NOTE: Check Service Manual for instructions and hydraulic oil specification before adding. **DO NOT OVERFILL.**

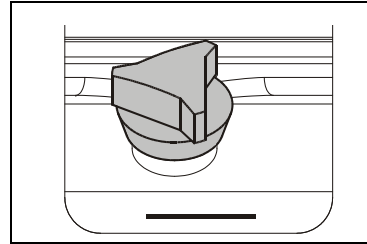

FILL TO LINE
on Hydraulic
Reservoir
indicates the
proper level for
hydraulic oil.

7. **Function Check** – Check all machine controls for operation per *Section 2.5, Function Check*.

If optional equipment is installed on this machine refer to Section 3 for specific Pre-Start Inspection and Operation instructions.

2.4 DAILY WALK-AROUND INSPECTION

Begin the “Walk-Around Inspection” at item one (1) as noted on the diagram. Continue around machine check each item in sequence for the conditions listed in the following check list.

WARNING

TO AVOID POSSIBLE INJURY, BE SURE MACHINE POWER IS “OFF” DURING “WALK-AROUND INSPECTION”.

DO NOT OPERATE MACHINE UNTIL ALL MALFUNCTIONS HAVE BEEN CORRECTED.

NOTICE

DO NOT OVERLOOK VISUAL INSPECTION OF THE BASE FRAME UNDERSIDE. CHECK THIS AREA FOR OBJECTS OR DEBRIS WHICH COULD CAUSE EXTENSIVE MACHINE DAMAGE.

INSPECTION NOTE: *On all components, make sure there are no loose or missing parts, that they are securely fastened, and that no visible damage, leaks or excessive wear exists in addition to any other criteria mentioned.*

1. **Drive and Caster Wheels** - Check for any debris stuck to or around wheels.

2. **Base Frame** - Check pot-hole-protection system components; check for loose wires or cables dangling below the base.
3. **Manual Descent Control Valve** - See inspection note above.
4. **Motor/Pump/Reservoir Unit** - No evidence of hydraulic leaks. Hydraulic oil level should be filled level with the full line.
5. **Batteries** - Charge if necessary.
6. **Platform Assembly and Gate** - Quick-Change platform mounting and mounting pins; platform railings; entry bar or gate in proper working order; MSP - platform fasteners.
7. **Platform Control Console** - Platform control; placards secure and legible; emergency stop switch reset for operation; Control markings legible.
8. **Ground Control Station** - Main Power Selector Switch operable; placards secure and legible; emergency stop switch operates properly.
9. **Mast Assembly** - Mast sections; slide pads; mast chains; sequencing cables; platform control and power cables (*on side of mast*); power cables properly tensioned and seated in sheaves; cable sheaves rotating freely.

SECTION 2 - PREPARATION AND INSPECTION

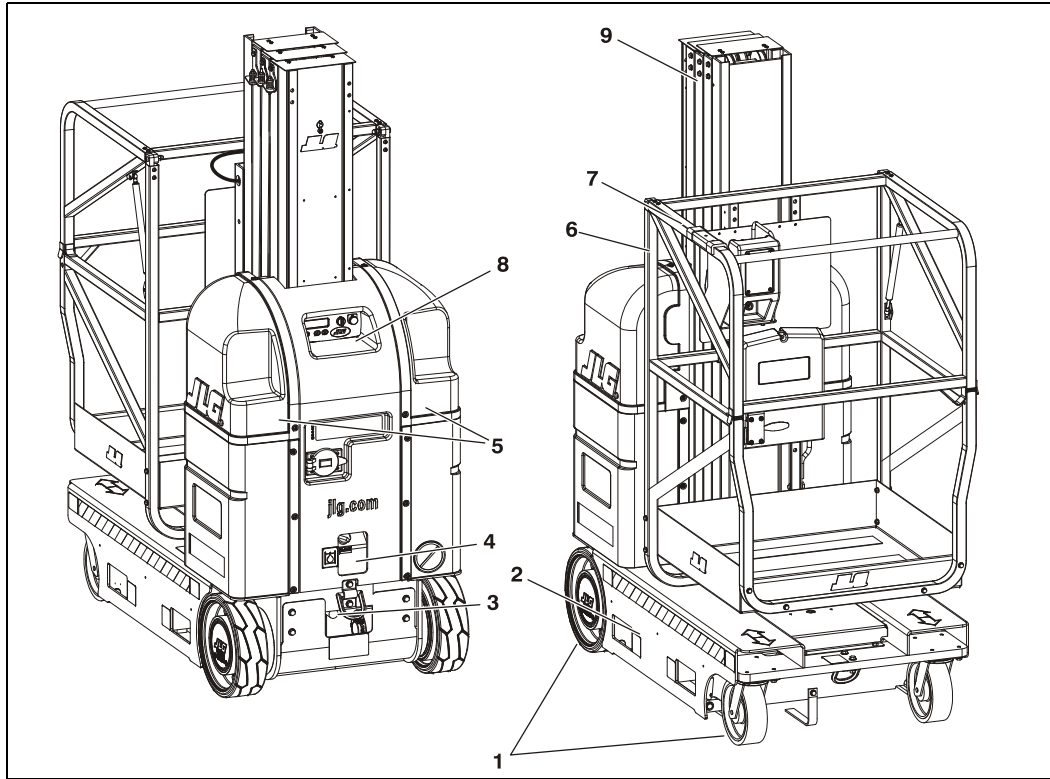

1. Drive and Caster Wheels
2. Base Frame
3. Manual Descent Control Valve
4. Motor/Pump/Reservoir Unit
5. Batteries - (Inside Cover)
6. Platform Assembly
7. Platform Control Console
8. Ground Control Station
9. Mast Assembly

Figure 2-1. Daily Walk-Around Inspection for MVL/MSP Machines.

2.5 Function Check

Once the “Walk-Around” Inspection is complete, perform a function check of all systems in an area free of overhead and ground level obstructions. Refer to Section 3 for more specific operating instructions.

⚠ WARNING

IF THE MACHINE DOES NOT OPERATE PROPERLY, TURN OFF THE MACHINE IMMEDIATELY! REPORT THE PROBLEM TO THE PROPER MAINTENANCE PERSONNEL. DO NOT OPERATE THE MACHINE UNTIL IT IS DECLARED SAFE FOR OPERATION.

Perform a Function Check as follows:

1. **From the ground controls with no load in the platform:**
 - a. Operate ground control functions, platform lift up and lift down.
 - b. Ensure Pot-Hole-Protection device is fully engaged (bars down on sides) when the platform is elevated (See Figure 2-2.).
 - c. Ensure that all machine functions are disabled when the Emergency Stop Button is activated.
 - d. Check Manual Descent Control valve is operating properly.

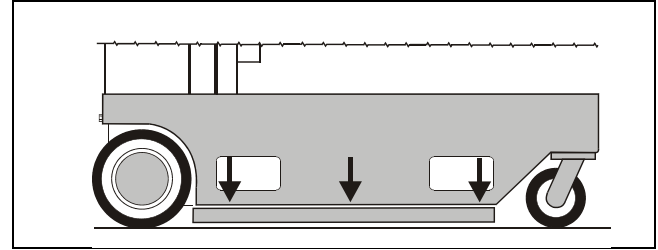

Figure 2-2. Pot-Hole-Protection Bars Lowered.

2. **From the platform control console:**
 - a. Ensure that the control console is properly mounted and secure.
 - b. Raise and lower platform 2 ft. to 3 ft. (.61m to .92 m) several times. Check for smooth elevation and lowering of platform.
 - c. Operate all functions, check all limit, cut-out, and enable switches are functioning properly:
 - **Machine Brakes** - Drive the machine on a grade, (**do not exceed the rated gradability**), and stop to ensure the brakes hold.
 - **Tilt Warning Limit** - With the platform completely lowered, drive the machine onto a surface with a tilt of more than 1.5° in any direction (**do not exceed rated gradability**). The

SECTION 2 - PREPARATION AND INSPECTION

machine will indicate a tilt condition if any attempt is made to elevate the platform.

- **Drive Speed Reduction Limit** - When platform is elevated more than 1.5 to 2 ft. (.5m) drive speed is cut to 1/4 of platform lowered drive speed.

- **Platform Joystick Enable Trigger** - The machine will not operate (drive or lift) unless this switch is pressed and held during drive or lift operation.

- d. Ensure all machine functions are disabled when the Emergency Stop Button is activated (pressed in).

SECTION 3. MACHINE CONTROLS, INDICATORS AND OPERATION

3.1 GENERAL

NOTICE

THE MANUFACTURER HAS NO DIRECT CONTROL OVER MACHINE APPLICATION AND OPERATION. THE USER AND OPERATOR ARE RESPONSIBLE FOR CONFORMING WITH GOOD SAFETY PRACTICES.

This section provides the necessary information needed to understand control function and operation.

3.2 MACHINE DESCRIPTION

The JLG MVL/MSP Model Lifts are electric self-propelled machines with an aerial work platform mounted to an elevating aluminum mast mechanism. The personnel lift's intended purpose is to provide personnel access to areas above ground level. The MSP model lift is intended for stock picking purposes in retail stores or warehouses.

The primary control station is located in the platform. From the Platform Control Console the operator can drive the machine and raise or lower the platform.

The controls of the programmable Ground Control Station are to be used during machine power-up, machine maintenance or in case of emergency should the operator in the platform be unable to lower the platform.

Vibrations emitted by these machines are not hazardous to an operator working in the platform.

The continuous A-Weighted sound pressure level at the work platform is less than 70db (A).

3.3 MACHINE OPERATION

Getting Started

The following control conditions must be met before the machine can be operated from either the Ground or Platform Controls.

- The batteries contain enough voltage to operate the machine.
- The Main Power Selector Switch on the Ground Control Station must be set for either Ground Control Mode or Platform Control Mode.
- Both Emergency Stop Switches, one on the Ground Control Station the other on the Platform Control Console must be in the RESET position.
- If equipped, the On/Off Key Switch on the Platform Console must be set to the ON position.

3.4 BATTERY CHARGING

This machine is equipped with an AC voltage input/DC voltage output battery charger. The charger automatically terminates charging when the batteries reach full capacity.

NOTE: *The platform drive function is disabled when the battery charger is plugged into an AC receptacle.*

WARNING





LEAD ACID BATTERIES MAY GENERATE EXPLOSIVE HYDROGEN GAS DURING NORMAL OPERATION. KEEP SPARKS, FLAMES, AND SMOKING MATERIALS AWAY FROM BATTERIES. PROVIDE ADEQUATE VENTILATION DURING CHARGING. NEVER CHARGE A FROZEN BATTERY. STUDY ALL BATTERY MANUFACTURERS' SPECIFIC PRECAUTIONS SUCH AS RECOMMENDED RATES OF CHARGE AND REMOVING OR NOT REMOVING CELL CAPS WHILE CHARGING.

SECTION 3 - MACHINE CONTROLS, INDICATORS AND OPERATION

Battery - Low Voltage Warning Indicators

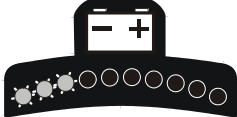
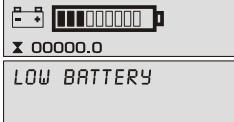
The MVL/MSP Platform Control Console and Ground Control Station indicate battery low voltage at three (3) Warning Levels.

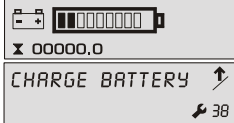
Table 3-1. Battery Low Voltage Warning Indicators.

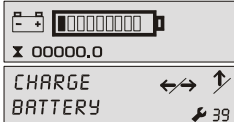
WARNING LEVEL	INDICATOR LOCATION		RESULT	ACTION REQUIRED TO CLEAR FAULT
	PLATFORM CONTROL LED	GROUND CONTROL LCD		
LEVEL-1			<ul style="list-style-type: none"> • 3 LEDs/BARS Flashing with an audible beep. • Machine will Operate - No Control Functions Locked Out. 	Charge batteries to a level of four (4) LEDs/BARS or more before operating.
LEVEL-2			<ul style="list-style-type: none"> • 2 LEDs/BARS Flashing with an audible beep. • Platform Lift-UP Function is Locked Out. 	Charge batteries for a minimum of four (4) continuous hours or eight (8) LEDs/BARS lit before operating. (a)
LEVEL-3			<ul style="list-style-type: none"> • 1 LED/BAR Flashing with an audible beep. • Drive and Platform Lift-UP Functions Locked Out. 	Charge batteries for a minimum of four (4) continuous hours or eight (8) LEDs/BARS lit before operating. (a)

NOTE: (a) To maximize battery life, it is recommended that the factory supplied batteries be charged continuously for a minimum of 4 hours or until 8 bars are lit on the ground station LCD Display before operating the machine. When drained to Warning Level 2 or 3, batteries must be charged until 8 bars are lit on the ground station LCD display to clear the fault code.

SECTION 3 - MACHINE CONTROLS, INDICATORS AND OPERATION

To Charge Batteries

1. Park machine in a well ventilated area near an AC voltage electrical outlet.
2. Always use a grounded AC outlet. Connect charger to an outlet that has been properly installed and grounded in accordance with all local codes and ordinances. A grounded outlet is required to reduce risk of electric shock – do not use ground adapters or modify plug. When using an extension cord, avoid excessive voltage drops by using a grounded 3-wire 12 AWG cord.

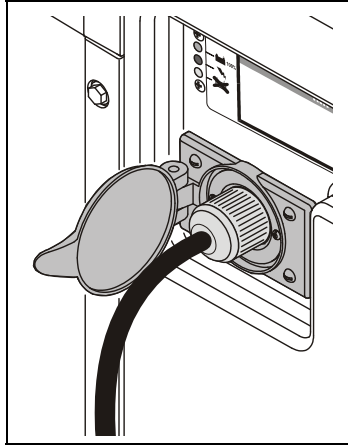

Battery Charging Status Indicators

The battery charging status indicators are located just above the Charger AC input receptacle on the center cover section at the rear of the machine. (See Figure 3-1. on page 3-8)

1. When plugged in the charger will automatically turn on and run through a short LED indicator self-test (all LED's will flash in an up-down sequence for two seconds).
2. The YELLOW 'CHARGING' LED will turn on and a trickle current will be applied until a minimum voltage is reached.

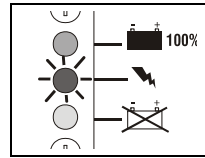

CHARGING

YELLOW (MIDDLE) LED ON
Charge Incomplete

Once a minimum battery voltage of 2 volts per cell is detected, the charger will enter the bulk charging constant-current stage and the YELLOW 'CHARGING' LED will remain on. The length of charge time will vary by how large and how depleted the battery pack is, the input voltage (the higher, the better), and ambient temperatures (the lower, the better). If the input AC voltage is low (below 104VAC), then the charging power will be reduced to avoid high input currents. If the ambient temperature is too high, then the charging

SECTION 3 - MACHINE CONTROLS, INDICATORS AND OPERATION

power will also be reduced to maintain a maximum internal temperature.

- When the GREEN 'CHARGED' LED turns on, the batteries are completely charged.

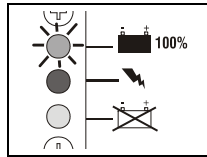

CHARGE COMPLETE

GREEN (TOP) LED ON
100% Complete

The charger may now be unplugged from AC power (*always pull on plug and not cord to reduce risk of damage to the cord*). If left plugged in, the charger will automatically restart a complete charge cycle if the battery pack voltage drops below a minimum voltage or 30 days has elapsed.

- If a fault occurred anytime during charging, a fault indication is given by flashing the RED 'FAULT' LED with a code corresponding to the error.

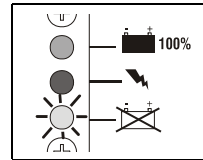

CHARGING PROBLEM

RED (BOTTOM) LED ON
See Flash Codes following

There are several possible conditions that generate errors. Some errors are serious and require human intervention to first resolve the problem and then to reset the charger by interrupting AC power for at least 10 seconds. Others may be simply transient and will automatically recover when the fault condition is eliminated. To indicate which error occurred, the RED 'FAULT' LED will flash a number of times, pause, and then repeat.

[1 FLASH] Battery Voltage High: auto-recover. Indicates a high battery pack voltage.

[2 FLASH] Battery Voltage Low: auto-recover. Indicates either a battery pack failure, battery pack is not connected to charger, or battery volts per cell is less than 0.5 VDC. Check the battery pack and battery pack connections.

SECTION 3 - MACHINE CONTROLS, INDICATORS AND OPERATION

[3 FLASH] Charge Timeout: Indicates the battery did not charge within the allowed time. This could occur if the battery is of a larger capacity than the algorithm is intended for. It can also occur if the battery pack is damaged, old, or in poor condition. In unusual cases it could mean charger output is reduced due to high ambient temperature.

[4 FLASH] Check Battery: Indicates the battery pack could not be trickle charged up to the minimum 2 volts per cell level required for the charge to be started. This may also indicate that one or more cells in the battery pack are shorted or damaged.

[5 FLASH] Over-Temperature: auto-recover. Indicates charger has shutdown due to high internal temperature which typically indicates there is not sufficient airflow for cooling – see step 1 of Installation Instructions. Charger will restart and charge to completion if temperature is within accepted limits.

[6 FLASH] QuikQ Fault: Indicates that the batteries will not accept charge current, or an internal fault has been detected in the charger. This fault will nearly always be set within the first 30 seconds of operation. Once it has been determined that the batteries and connections are not faulty and Fault 6 is again displayed after interrupting AC power for at least 10 seconds, the charger must be brought to a qualified service depot.

3.5 GROUND CONTROL STATION - OPERATION

(See Figure 3-1.)

NOTE: If equipped with optional Programmable Security Lock (PSL) see Section 3.12 for additional instructions.

Main Power Selector Switch

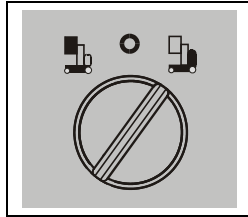

Set the Main Power Selector Switch to Ground Control Mode for Ground Control operation or Platform Control Mode for Platform Operation.

Emergency Stop/Shut Down Button

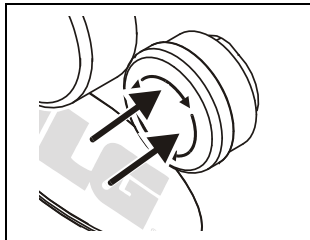

POWER OFF

PUSH IN -

To Engage
Emergency Stop

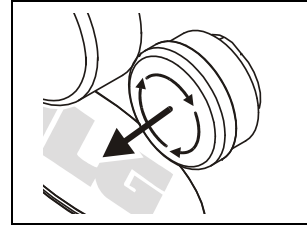

POWER ON

**TURN CLOCKWISE
and RELEASE -**

To Reset
Emergency Stop

Brake Release Button



DO NOT MANUALLY DISENGAGE THE BRAKES UNLESS MACHINE IS SETTING ON A LEVEL SURFACE OR MACHINE IS FULLY RESTRAINED.

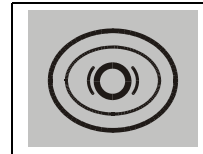

**PUSH and RELEASE -
TO DISENGAGE Brakes**

**PUSH and RELEASE AGAIN -
TO ENGAGE Brakes**

NOTE: The brakes only *DISENGAGE* (electrically) when the joystick control is moved off center during driving or are manually *DISENGAGED* (electrically) using the the Brake Release Button.

If the machine's batteries are completely depleted of electrical charge the brakes cannot be released manually.

SECTION 3 - MACHINE CONTROLS, INDICATORS AND OPERATION

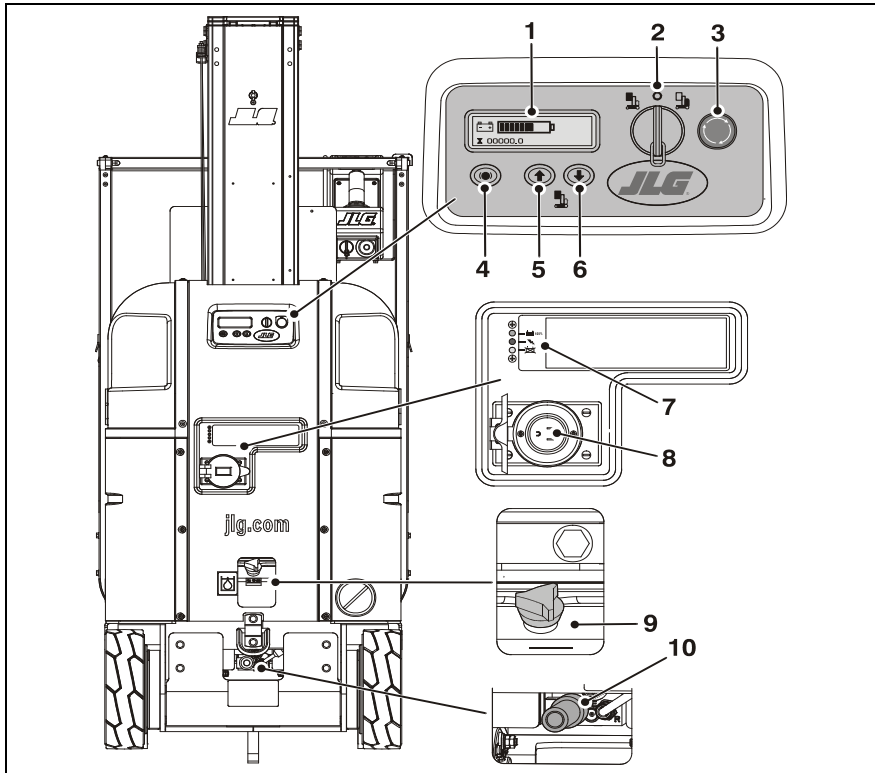

Figure 3-1. Ground Control Station. (Machine Rear View)

Ground Control Module

1. Machine Status LCD Display
2. Main Power Selector Switch
3. Emergency Stop
4. Brake Release
5. Platform Up
6. Platform Down

Battery Charging Station

7. Battery Charging Status Indicators
8. Charger A/C Input Receptacle

Hydraulic System

9. Hydraulic Oil Reservoir
10. Manual Descent Control Valve

NOTE: The Ground Control Station Module is fully programmable. For operator level programmability see Section 5.4, GROUND CONTROL STATION - PROGRAMMING.

NOTE: If equipped with optional Programmable Security Lock (PSL) see Section 3.12 on page 3-36 for additional machine power-up instructions.

SECTION 3 - MACHINE CONTROLS, INDICATORS AND OPERATION

Platform Up

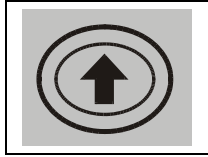

PUSH IN -
TO ELEVATE Platform
RELEASE -
TO STOP ELEVATING

Platform Down

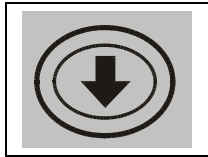

PUSH IN -
TO LOWER Platform
RELEASE -
TO STOP LOWERING

Manual Descent Control Valve

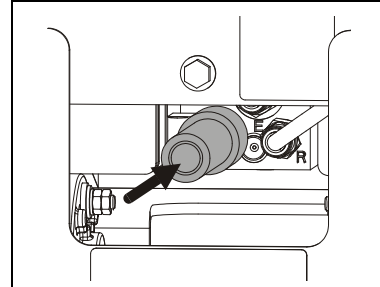

PUSH-IN TO
LOWER Platform

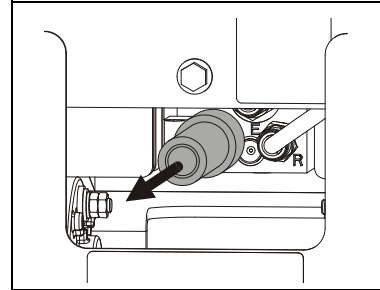

RELEASE TO -
STOP Platform
Descent

SECTION 3 - MACHINE CONTROLS, INDICATORS AND OPERATION

Machine Status LCD Display

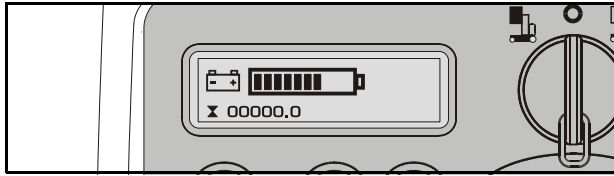

At power-up and during operation the LCD display on the Ground Control Module displays the current machine operating status. The following illustration explains the symbol indications.

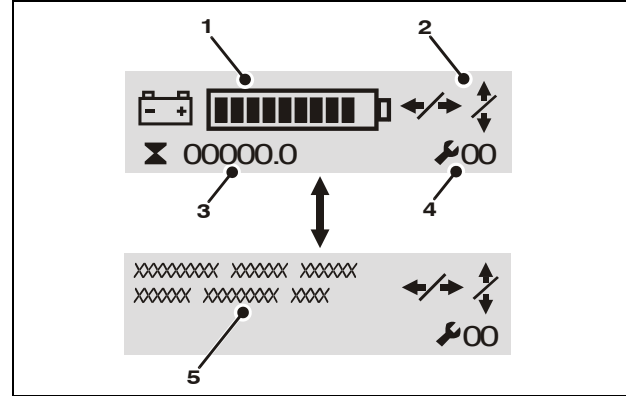

LCD Display Symbols

1. Battery Charge Indicator (BCI)
2. Function Display or Function Disabled Indicators
3. Hour Meter Display
4. Fault Code Indicator
5. Fault Text Message Display (a)

Note: (a) When an Fault Code is indicated the LCD screen will alternate between the text and symbol display modes.

SECTION 3 - MACHINE CONTROLS, INDICATORS AND OPERATION

In the LCD Display Symbols illustration item (2), the Function Display or Function Disabled Indicators will vary as shown following:

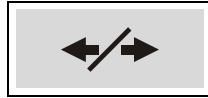

DRIVE Disabled



LIFT UP Disabled



LIFT DOWN Disabled



Both LIFT UP and LIFT DOWN Disabled



Drive Speed Cut-Back -
Turtle Mode Engaged
(When Platform is Elevated)



Battery Charger (AC) Plugged In

LCD Display Fault Conditions





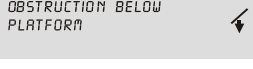
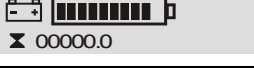
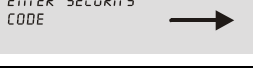
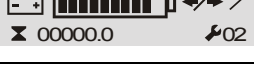

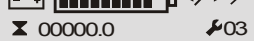

Table 3-2, LCD Display - Operation Fault Conditions show common LCD display Fault indications which may occur during operation and are usually caused by either an error in machine operation or a work area condition. These fault conditions can usually be corrected by the operator and do not require a qualified mechanic to repair.

NOTICE

AFTER A FAULT CONDITION IS CORRECTED THE MACHINE POWER MAY NEED TO BE RECYCLED TO RESET THE GROUND CONTROL STATION.

SECTION 3 - MACHINE CONTROLS, INDICATORS AND OPERATION

Table 3-2. LCD Display - Operation Fault Conditions

FAULT CODE	PLATFORM LEDS FLASHING	LCD SYMBOL SCREEN	LCD TEXT SCREEN	FAULT DESCRIPTION/ MACHINE CONDITION	LOOK FOR THIS
—	—			Brakes Released (DRIVE Disabled)	To Engage Brakes - Press Brake Release Button on Ground Control Station
—	—		NONE	Charger AC Plugged In DRIVE Disabled	Unplug Charger AC Power Cord
—	—			Obstruction Sensor System (Platform Elevated) LIFT DOWN Disabled	Obstruction Under Platform or Sensor Defective
—	—			Programmable Security Lock Password	Enter Code on PSL Keypad to Power-Up Machine
2	2			Left PHP Bar UP (Platform Elevated) DRIVE and Lift UP Disabled	Lower Platform and Check the Left Pot Hole Protection Bar
3	2			Right PHP Bar UP (Platform Elevated) DRIVE and Lift UP Disabled	Lower the Platform and Check the Right Pot Hole Protection Bar



SECTION 3 - MACHINE CONTROLS, INDICATORS AND OPERATION

Table 3-2. LCD Display - Operation Fault Conditions (Continued)

FAULT CODE	PLATFORM LEDS FLASHING	LCD SYMBOL SCREEN	LCD TEXT SCREEN	FAULT DESCRIPTION/ MACHINE CONDITION	LOOK FOR THIS
4	3			Tilt Condition (Platform Elevated) DRIVE and Lift UP Disabled	Lower the Platform and Drive off the Tilt Condition
6	8			Drive Motor Brush Wear Warning (25 hrs. of DRIVE operation remaining to a 10 sec. shut down mode)	Drive Motor Brushes Require Service Replacement - (See Section 5.5 on page 5-20 for further Instructions)
13	6			Traction Module Over Temperature (DRIVE Disabled)	Allow Drive System Traction Module to Cool Before Operating
17	7			Ground Control Module Over Temperature (Machine Stopped)	Allow Ground Control Module to Cool Before Operating
32	7			Pump Motor Over Current (LIFT UP Disabled)	Platform Load Over Capacity
33	2			Both PHP Bars UP DRIVE and Lift UP Disabled	Check for Object Blocking Both the Left and Right PHP Bars

SECTION 3 - MACHINE CONTROLS, INDICATORS AND OPERATION

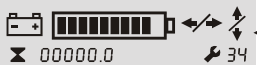
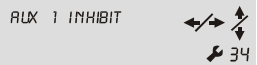
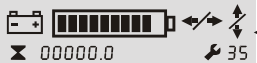
Table 3-2. LCD Display - Operation Fault Conditions (Continued)

FAULT CODE	PLATFORM LEDS FLASHING	LCD SYMBOL SCREEN	LCD TEXT SCREEN	FAULT DESCRIPTION/ MACHINE CONDITION	LOOK FOR THIS
34	—			Aux. #1 - Platform Gate Open or No Pressure on the Platform Enable switch.	Close Platform Gate or Depress Platform Enable switch during machine operation.
35	—			Aux. #1 - Platform Enable switch depressed during Machine Power-up.	Do Not Press on Platform Enable switch during Machine Power-Up.
<p>NOTE: The fault conditions shown above are fault conditions which the Operator may be able to resolve. Should a fault occur and be displayed on the LCD screen which cannot be corrected at the Operator's level, the problem must be referred to a qualified JLG mechanic. A complete table of Fault Codes is listed in the TroubleShooting Section of the Service and Maintenance Manual.</p>					

3.6 PLATFORM CONTROL CONSOLE OPERATION

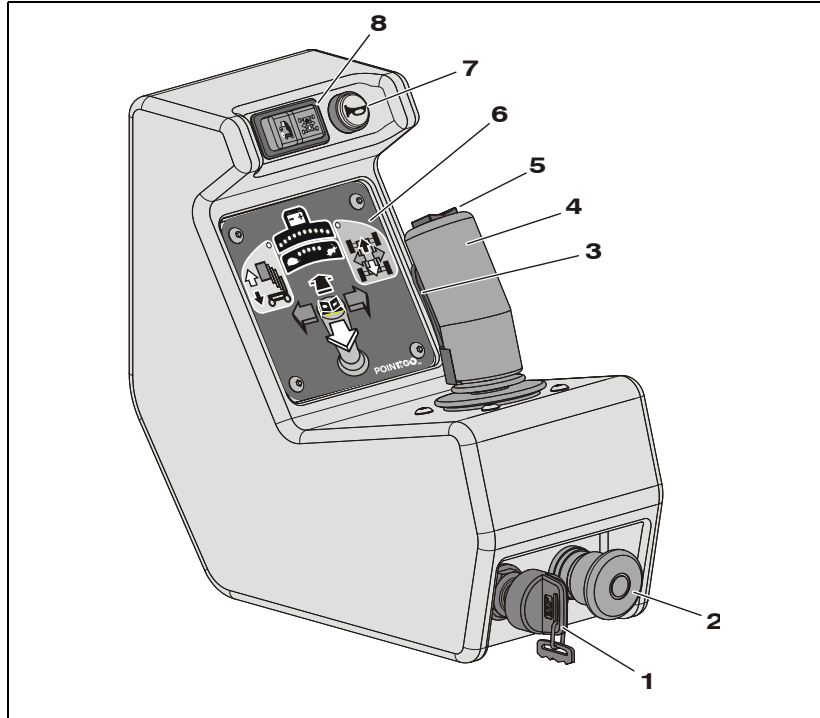

1. On/Off Key Switch -
(See page 3-16)
2. Emergency Stop/Shut Down Button -
(See page 3-17)
3. Function Enable Lever - *(on front of joystick)*
(See page 3-19)
4. Multifunction Joystick Control -
(See page 3-20)
5. Drive Speed Setting Selector Switch -
(See page 3-23)
6. Platform Control Display Panel -
(See page 3-17)
7. Horn Button - (See page 3-19)
8. Drive/Lift Mode Selector Switch -
(See page 3-19)

Figure 3-2. Platform Control Console

SECTION 3 - MACHINE CONTROLS, INDICATORS AND OPERATION

General

The following conditions must be met before the machine can be operated from the platform control console:

- Ground Control Station - Main Power Selector Switch must be set to PLATFORM CONTROL MODE.
- Ground Control Station - Emergency Stop/Shut Down Button must be in the RESET position (POWER ON).

NOTE: See Section 3.5 on page 3-7, for Ground Control Station operation.

- Platform Console - On/Off Key Switch must be set to the ON position.
- Platform Console - Emergency Stop/Shut Down Button must be in the RESET position (POWER ON).
- If equipped with the OPTIONAL - PSL (*Programmable Security Lock* - Section 3.12 on page 3-36) it must be set to the ON position.

NOTE: **SLEEP MODE** - During operation if no control functions have been activated for 10 minutes (default programmable setting), the ground control module will power the machine down to conserve battery power. Cycle power back on using either the main power selector switch (key) or the emergency stop/power down button on either the platform controller or the ground control station.

Platform On/Off Key Switch

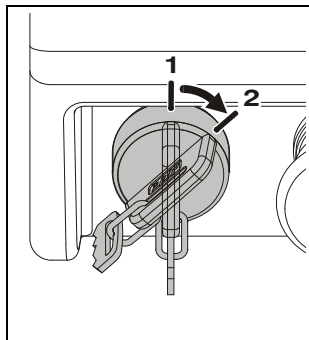

At the Platform Control Console - Set the On/Off Key Switch to the ON position (2) to operate machine.

1. OFF Position
2. ON Position

Set the ON/OFF Key Switch to the OFF position to power machine down.

NOTE: If necessary, when machine is not in use, remove key from platform key switch to disable machine from unauthorized use.

NOTE: During operation the operator in the platform can prevent unauthorized control of the machine (from the Ground Control Station) by either switching the On/Off Key to the OFF position, or activating the Emergency Stop Button on the platform control console.

Platform Emergency Stop Button

NOTE: The Platform and Ground Control Station Emergency Stop Buttons must both be in the RESET position to operate machine.

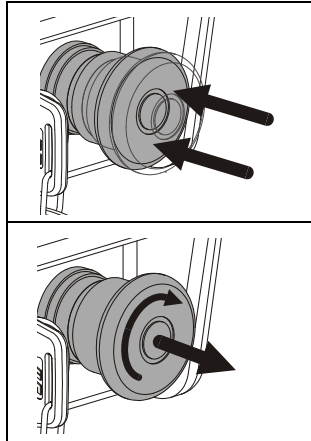

POWER OFF
PUSH IN -
TO ENGAGE
Emergency Stop

POWER ON
TURN CLOCKWISE
and RELEASE to
RESET Emergency Stop

Platform Control Display Panel

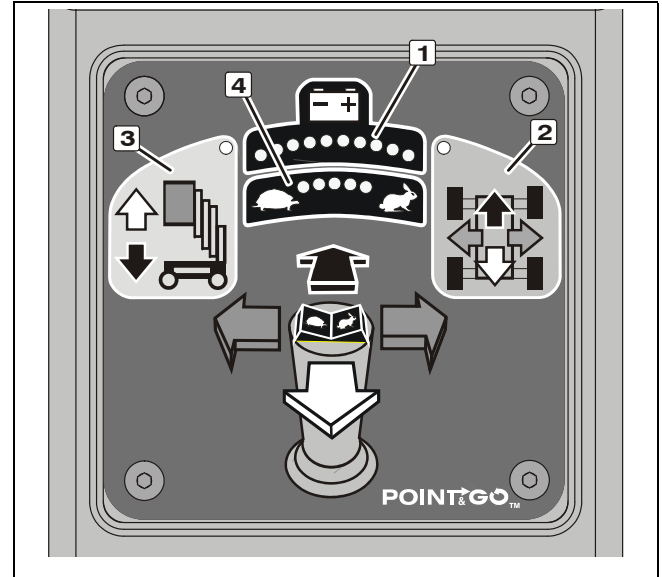

Figure 3-3. Platform Control Display Panel.

- 1. Battery Charge/Flash Code LEDs
- 2. Drive Mode Indicator
- 3. Lift Mode Indicator
- 4. Drive Speed Setting Indicator

SECTION 3 - MACHINE CONTROLS, INDICATORS AND OPERATION

1. Battery Charge/Flash Code Indicator LEDS

On normal power-up and operation this series of ten (10) LEDs visually indicates the amount of charge remaining in the batteries.

The number of LEDs lit will change depending on the level of charge in the batteries.

- (+) All Three (3) GREEN LEDs lit up indicate maximum battery charge.
- Four (4) YELLOW LEDs indicate a two thirds to one third battery charge remaining.
- (-) Three (3) RED LED's lit indicate minimum battery charge remaining. The machine will continue to operate at this charge level but will begin to indicate low battery voltage warning indicators.

NOTE: For more information on Battery Warning Level Indicators See "Battery - Low Voltage Warning Indicators" on page 3-3.

This set of ten (10) LEDs will also indicate a flash (fault) code if operating problems are detected by the Ground Control Station. Fault codes are also accompanied by a beeping alert from the platform control console.

NOTE: LED Flash (Fault) Code indications that can be corrected by the operator are shown on Table 3-2 on page 3-12, this section of the manual.

2. Drive Mode Indicator

When the Drive/Lift Mode Selector Switch is set to DRIVE MODE the round LED indicator on that portion of the display panel will light up indicating the DRIVE Mode active.

3. Lift Mode Indicator

When the Drive/Lift Mode Selector Switch is set to LIFT MODE the round LED indicator on that portion of the display panel will light up indicating the LIFT Mode active.

4. Drive Speed Setting Indicator

The five (5) GREEN LEDs on the top of this indicator display the drive speed setting with the TURTLE (*on the left*) representing the MINIMUM speed setting and the RABBIT (*on the right*) representing the MAXIMUM speed setting.

Drive/Lift Mode Selector Switch

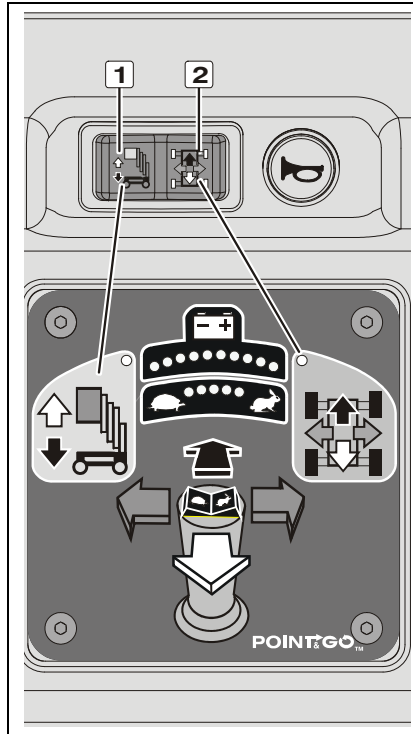

Drive/Lift Mode Selector Switch

1. LIFT Mode
2. DRIVE Mode

PUSH the rocker switch to select mode of operation.

Whichever mode is selected the appropriate LED indicator on the display panel below will light up showing which mode has been activated for joystick operation.

IMPORTANT:
The selected mode will only remain active for 5 seconds if the function is not operated.

Horn Button

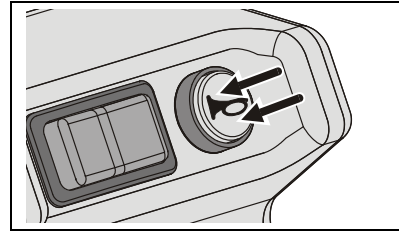

When the machine is powered on, pressing this button will sound the Horn.

Joystick Function Enable Lever

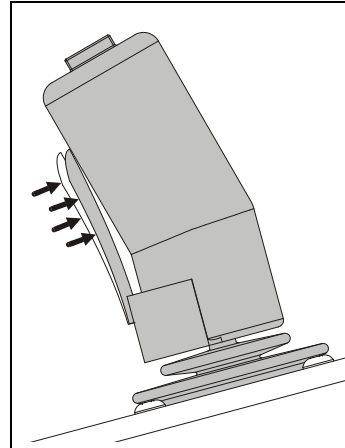

The Function Enable lever on the front of the joystick control, must be engaged and held in during any joystick operation.

SECTION 3 - MACHINE CONTROLS, INDICATORS AND OPERATION

Multifunction Joystick Control

The joystick will operate the following machine functions:

- Drive/Steer
- Platform Lift Up and Down

NOTE: Use the Drive/Lift Mode Selector Switch to select which function the joystick will operate. The selected operating mode will only remain active for 5 seconds if the function is not operated. Remember to press and hold the joystick function enable lever to operate any joystick functions.

⚠ WARNING

SEE FIGURE 3-4. ON PAGE 3-21 FOR GRADE AND SIDESLOPE DRIVING DESCRIPTION WHEN DRIVING WITH THE PLATFORM LOWERED (STOWED).

WHEN THE PLATFORM IS ELEVATED DRIVE ONLY ON A SMOOTH, FIRM, AND LEVEL SURFACE.

Drive Mode

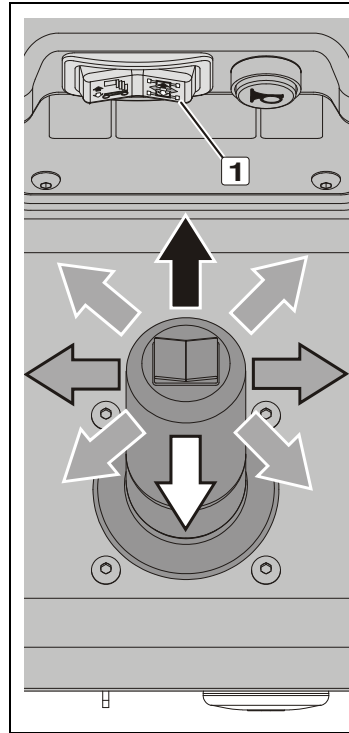

1. Activate the Drive Mode using the Drive/Lift Mode Selector switch.



Within 5 seconds of activation - ENGAGE and HOLD the JOYSTICK ENABLE LEVER then move the joystick in the desired direction of travel. Drive power is applied proportionally the further the joystick is moved off center.

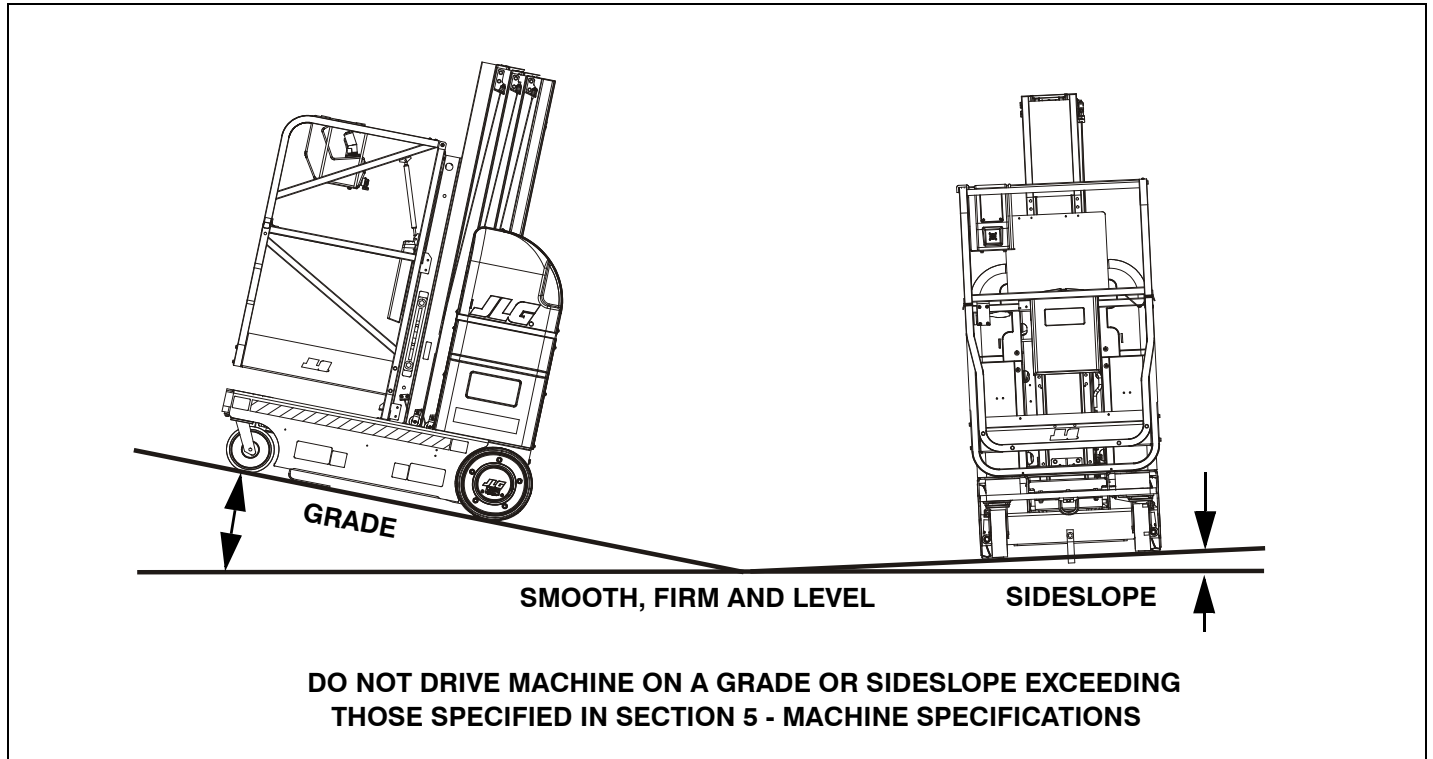
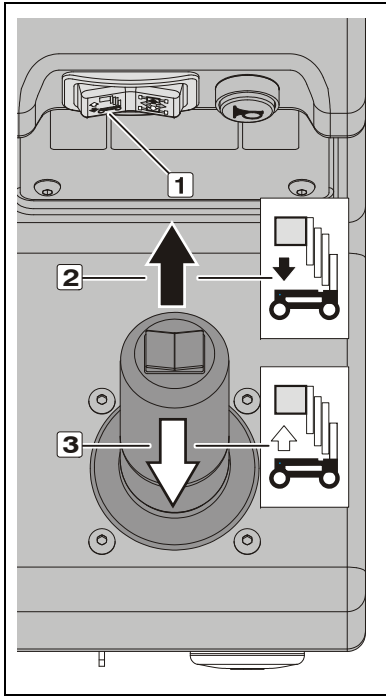

Figure 3-4. Machine Operating Specifications

SECTION 3 - MACHINE CONTROLS, INDICATORS AND OPERATION

Lift Mode



1. Activate the Lift Mode using the Drive/Lift Mode Selector switch.



2. Platform LIFT DOWN Direction
3. Platform LIFT UP Direction

Within 5 seconds of activation - ENGAGE and HOLD the JOYSTICK ENABLE LEVER then move the joystick in the direction of LIFT (3) OR LOWER (2).

! WARNING

IF THE TILT ALARM WARNING HAS BEEN ACTIVATED WHILE DRIVING WITH THE PLATFORM ELEVATED, LOWER PLATFORM COMPLETELY AND DRIVE TO A FIRM LEVEL SURFACE.

ENSURE THE AREA BENEATH THE PLATFORM IS FREE OF PERSONNEL PRIOR TO LOWERING THE PLATFORM.

Drive Speed Setting Controls

NOTE: When the platform is elevated the maximum drive speed is automatically cut-back to 1/4th the speed when the platform is fully lowered. The Ground Control Module-LCD screen will display a turtle when in this mode. See page 3-11 - Ground Control - LCD Status Display in this section of the manual.

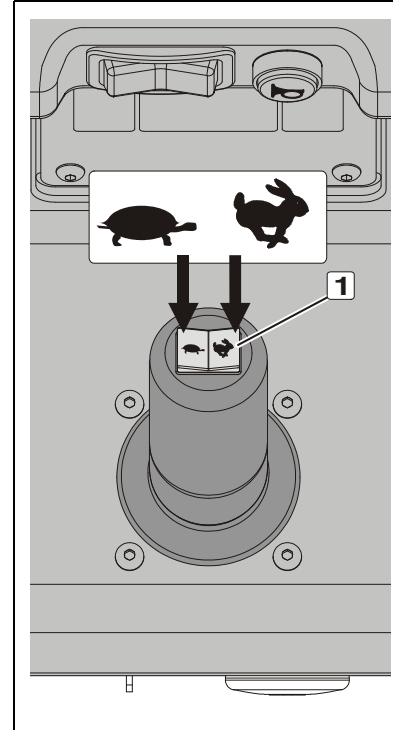
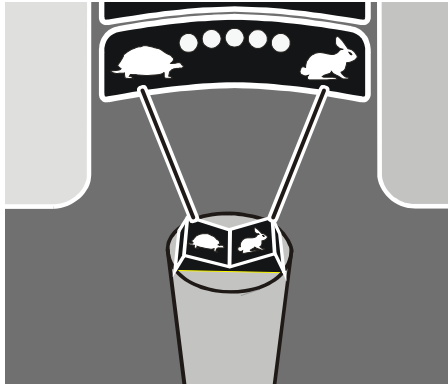

Drive Speed Setting Selector Switch

1. Selector Switch -
(on top of joystick)



Each PRESS on this side of the switch will DECREASE maximum drive speed.
(FEWER LEDs Lit up on the Drive Speed Indicator.)



Each PRESS on this side of the switch will INCREASE maximum drive speed.
(MORE LEDs Lit up on the Drive Speed Indicator.)

3.7 PARKING MACHINE

1. Drive machine to a well-protected and well-ventilated area.
2. Ensure the platform is fully lowered, turn the main power selector switch to the OFF position (*centered*).

NOTE: *If required, charge batteries in preparation for next work day.*

3.8 PLATFORM CONFIGURATIONS

The platforms in the following illustrations show the entry points as well as the direction of the platform gates for opening and closing when entering the platform. The maximum loading capacities per model are shown in the tables below each platform as well as the various components of the platform.

SECTION 3 - MACHINE CONTROLS, INDICATORS AND OPERATION

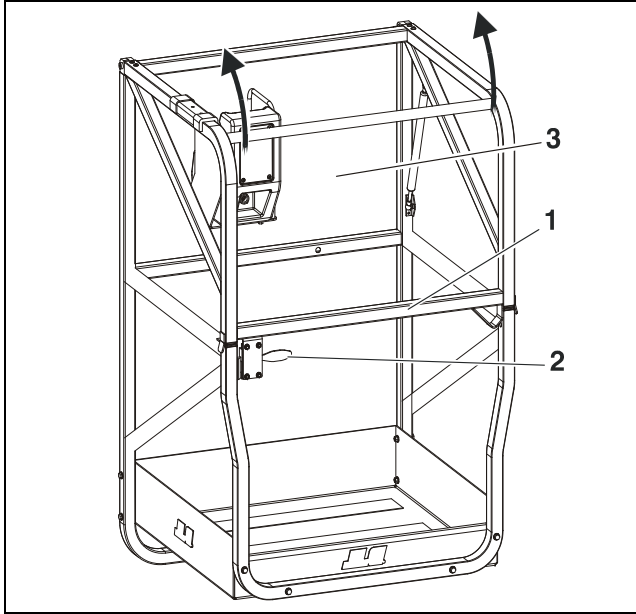

FRONT GULL-WING ENTRY PLATFORM (NON-CE and AUS)

Model	Max. Capacity
15MVL	500 lb. (230kg)
20MVL	350 lb. (160kg)
1. Front Gull-Wing Entry Gate 2. Entry Gate Latch	3. Lanyard Attach Point - (Left side on mast)

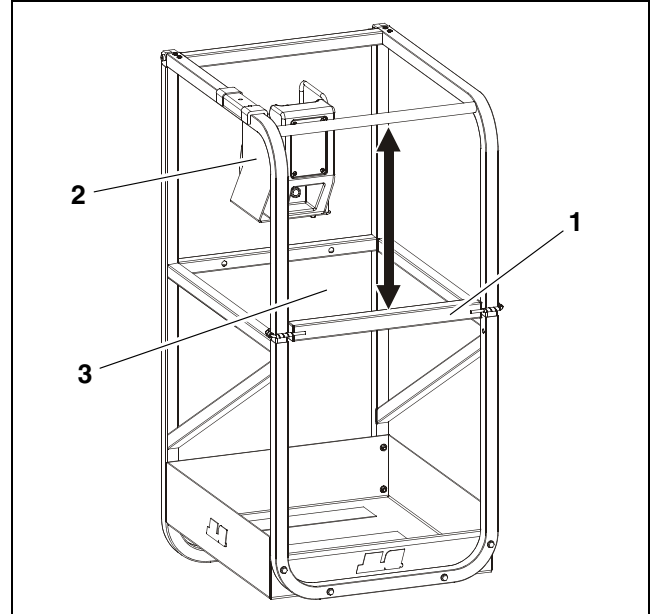

FRONT SLIDE BAR ENTRY PLATFORM

Model	Max. Capacity
15MVL	500 lb. (230kg)
20MVL	350 lb. (160kg)
1. Sliding Side Entry Gate 2. Platform Control Console	3. Lanyard Attach Point - (Left side on mast)

SECTION 3 - MACHINE CONTROLS, INDICATORS AND OPERATION

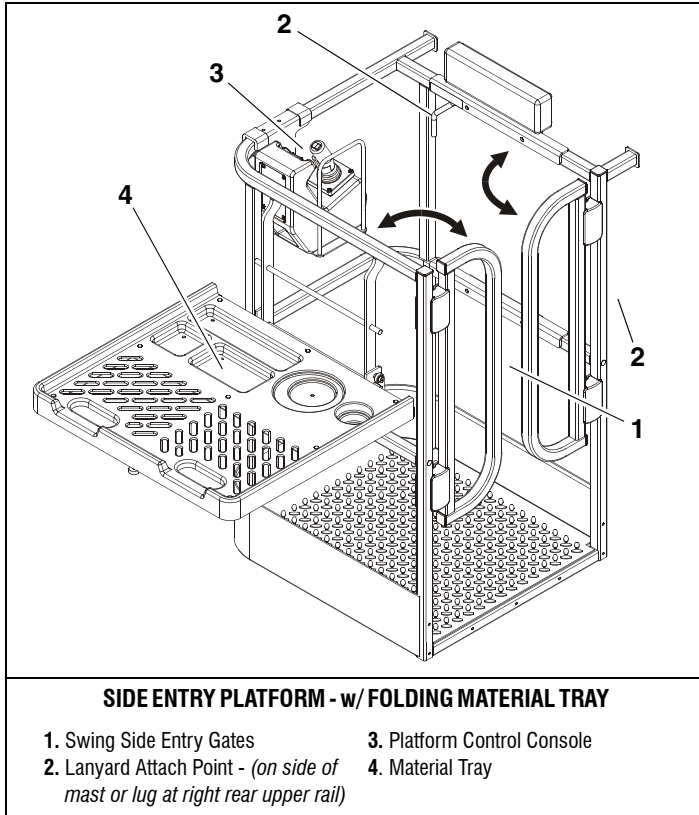

Table 3-3. Max. Capacity with Side Entry Platform w/Folding Material Tray Installed

SPEC	Model ⁽¹⁾	Platform Capacity	Tray Capacity	Combined Capacity
ANSI/CSA	15MSP	300 lb. (136 kg)	150 lb. (70 kg)	450 lb. (206 kg)
	20MSP	300 lb. (136 kg)	150 lb. (70 kg)	450 lb. (206 kg)
CE	20MVL	250 lb. (115 kg)	100 lb. (45 kg)	350 lb. (160 kg)
AUS	15MVL	350 lb. (160 kg)	150 lb. (70 kg)	500 lb. (230 kg)
	20MVL	250 lb. (115 kg)	100 lb. (45 kg)	350 lb. (160 kg)

⁽¹⁾ This platform is only available on models shown for the applicable specification.

NOTE: Australian Specification Machines ONLY - The SIDE ENTRY PLATFORM w/FOLDING MATERIAL TRAY includes a gate release/latch mechanism which is released by pressing down on the handles mounted to the top rail of both entry gates. Releasing the handles will latch the gates when closed.

SECTION 3 - MACHINE CONTROLS, INDICATORS AND OPERATION

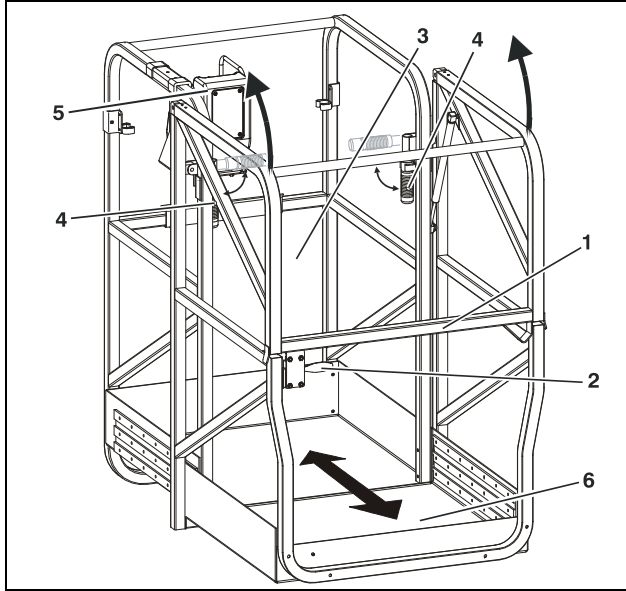

EXTENDIBLE PLATFORM (GULL-WING ENTRY - NON CE and AUS)

Model	Max. Capacity
15MVL/15MSP	500 lb. (230 kg)
20MVL/20MSP	350 lb. (160kg)
1. Gullwing Entry Gate 4. Extension Slide/Lock Handle 2. Entry Gate Latch 5. Platform Control Console 3. Lanyard Attach Point (on mast) 6. Sliding Extendible Section	

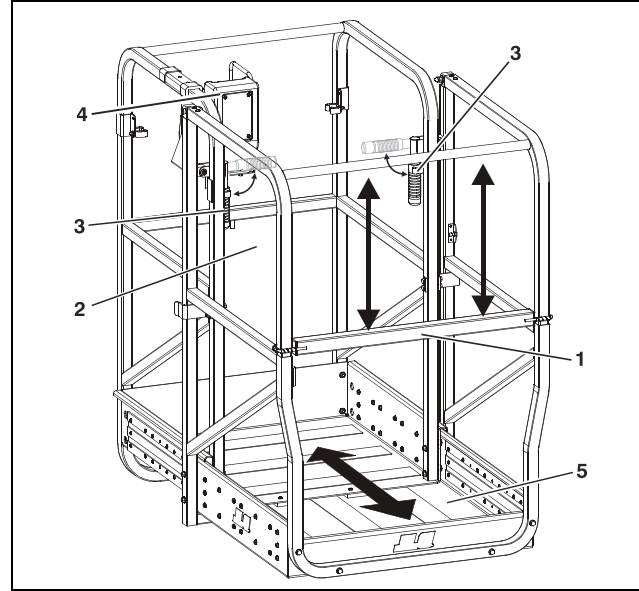

EXTENDIBLE PLATFORM (FRONT SLIDE BAR ENTRY - CE ONLY)

Model	Max. Capacity
15MVL/15MSP	500 lb. (230 kg)
20MVL/20MSP	350 lb. (160kg)
1. Sliding Bar Entry Gate 4. Platform Control Console 2. Lanyard Attach Point (on mast) 5. Sliding Extendible Section 3. Extension Slide/Lock Handle	

SECTION 3 - MACHINE CONTROLS, INDICATORS AND OPERATION

StockPicking Platform Operation

The stockpicking platform is available in two (2) versions.

- Fixed side-rail version
- Folding side-rail version

⚠ CAUTION

THE STOCKPICKER PLATFORM ALLOWS THE MACHINE TO BE OPERATED IN AN OPEN RAIL CONFIGURATION (SEE ILLUSTRATION).

CE SPECIFICATION MACHINES:

THE OPERATOR MUST WEAR A FULL BODY HARNESS EQUIPPED WITH A LANYARD SHORT ENOUGH TO PREVENT A FALL FROM THE PLATFORM. THE LANYARD MUST BE ATTACHED TO THE AUTHORIZED LANYARD POINT. ALSO, JLG RECOMMENDS THAT CE SPECIFICATION MACHINES EQUIPPED WITH THE STOCKPICKER PLATFORM ARE ONLY TO BE USED FOR STOCK-PICKING APPLICATIONS.

NON-CE UNITS:

THE OPERATOR MUST WEAR A FULL BODY HARNESS WITH A LANYARD (MAX. 6 FT. (1.82M)) ATTACHED TO THE AUTHORIZED LANYARD POINT OR A BODY BELT EQUIPPED WITH A LANYARD SHORT ENOUGH TO PREVENT A FALL FROM THE PLATFORM.

WHILE OPERATING THE MACHINE IN THE OPEN RAIL CONFIGURATION, ALWAYS OPERATE THE MACHINE FROM THE REAR OF THE PLATFORM WITH THE MID-GATE CLOSED AND THE PLATFORM CONTROL CONSOLE ATTACHED TO THE FIXED PORTION OF THE GUARDRAIL.

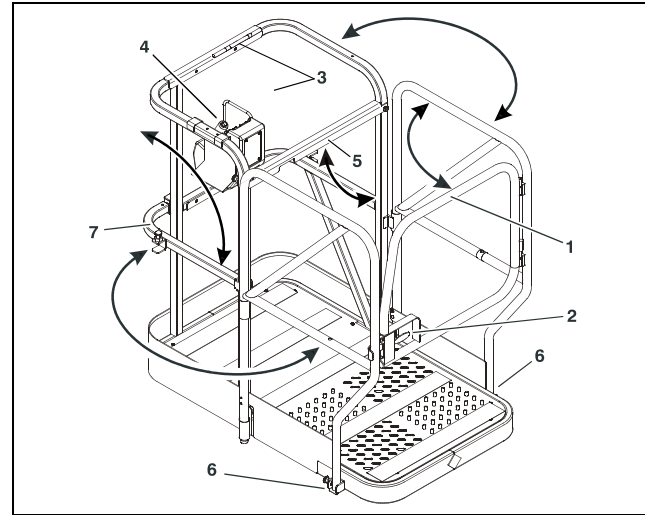

**STOCKPICKER PLATFORM
(WITH FOLDING SIDE-RAILS) (MSP)**

Model	Max. Capacity
15MSP	500 lb. (230 kg)
20MSP	400 lb. (180 kg)
1. Primary Entrance/Exit Gate	4. Platform Control Console
2. Primary Entrance Latch	5. Mid-Gate
3. Lanyard Attach Point - (on mast and platform rail)	6. Gate Release/Lock Pins
	7. Secondary Exit Gate

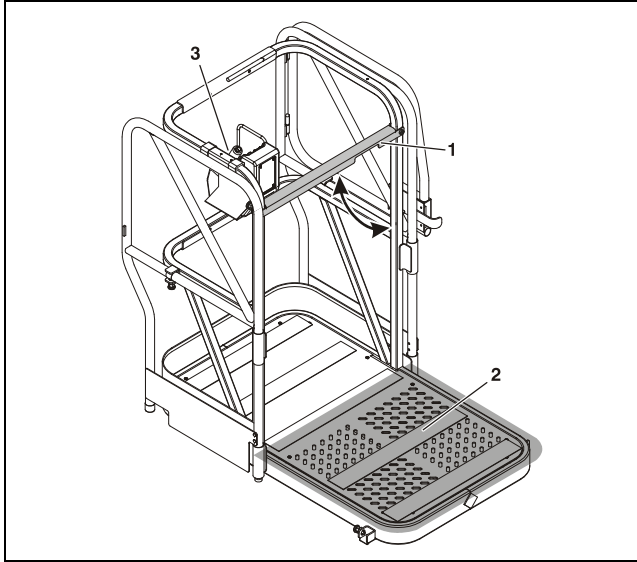

**STOCKPICKER PLATFORM
(OPEN RAIL CONFIGURATION) (MSP)**

1. Platform Mid-Gate (*enter platform behind mid-gate and close the mid-gate when driving with front rails open*).
2. Open Rail Configuration work area. (*See Caution on previous page about fall protection requirements*).
3. Platform Control Console attached to fixed side-rail in the rear of the platform.

3.9 FALL PROTECTION - LANYARD ATTACHMENT

⚠ CAUTION

JLG INDUSTRIES, INC. RECOMMENDS THE OPERATOR IN THE PLATFORM WEAR A FULL BODY HARNESS WITH A LANYARD ATTACHED TO AN AUTHORIZED LANYARD ANCHORAGE POINT.



The lanyard attach point for MVL/MSP machines depends on the type of platform attached to the machine.

- Quick Change (removable) platforms use a lanyard attach point located on the lower left side of the mast header, just behind the platform (see illustration).
- Fixed platforms (bolted permanently to the mast), have lanyard attach points located on the mid or upper platform rail at the rear of the platform. See specific platform illustration starting at “PLATFORM CONFIGURATIONS” on page 3-24.

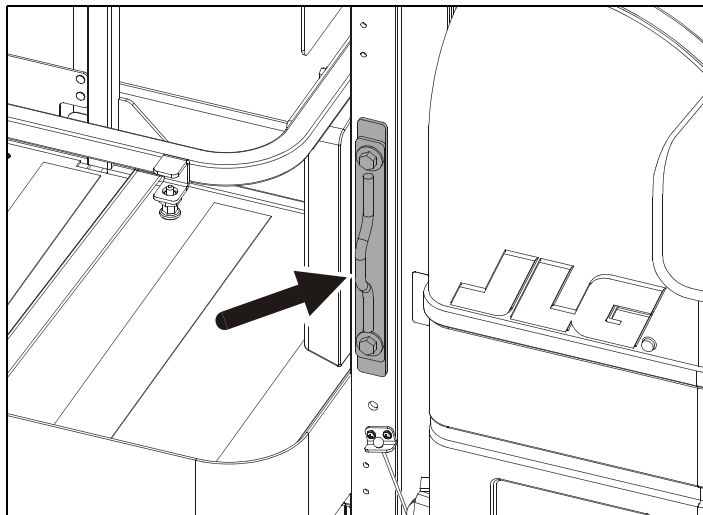

⚠ CAUTION

AFTER ENTERING THE PLATFORM, BEFORE BEGINNING OPERATION ALWAYS CLOSE THE PLATFORM ENTRY GATE(S).

3.10 QUICK-CHANGE PLATFORM MOUNTING

MVL Model Lifts are equipped with quick-change platform mounts which allow quick removal and installation of currently available quick-change platforms.

NOTE: MSP Models require the installation of the Quick-Change mount kit to use Quick-Change Platforms.

Platform Removal (see illustration following)

1. Remove the platform control console from the platform and lay aside.
2. Remove both upper and lower mount attach pins securing the platform support rails to the mast mounting channels.
3. Swing and lift the platform out of the mounts and lay aside.

Platform Installation

1. Set platform in upper and lower mounts.
2. Install attach pins in upper and lower mounts.
3. Attach platform control console to platform rail.

⚠ WARNING

ENSURE ALL PINS AND FASTENERS ARE INSTALLED AND SECURE PRIOR TO OPERATION.

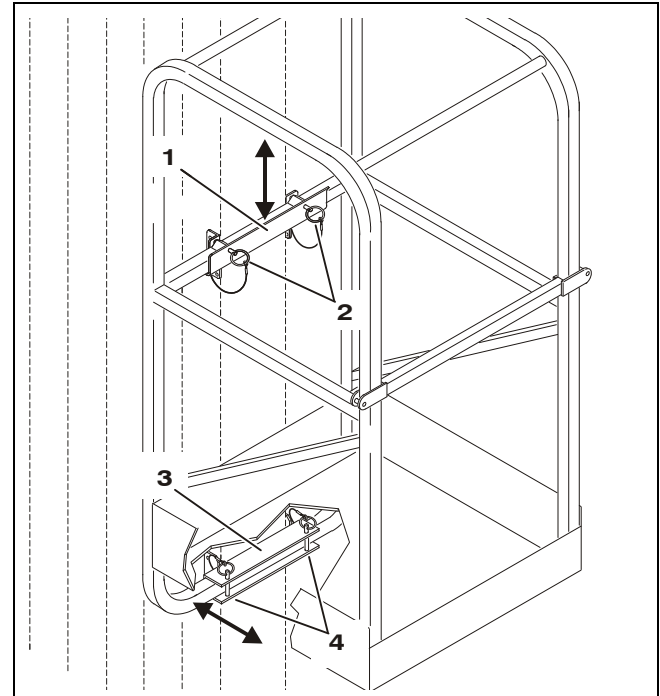

Quick-Change Platform Mounting

- | | |
|----------------------------|-------------------------|
| 1. Upper Platform Mount | 3. Lower Platform Mount |
| 2. Upper Mount Attach Pins | 4. Lower Mount Pins |

SECTION 3 - MACHINE CONTROLS, INDICATORS AND OPERATION

3.11 TRANSPORTING, LIFTING AND TIE DOWN PROCEDURES

General

All MVL and MSP Model Personnel Lifts may be transported to a work site using the following methods:

- Driving the machine around on its base wheels if travel surface area permits.
- Loaded, IN AN UPRIGHT POSITION ONLY onto a heavy-duty vehicle with the payload capacity capable of supporting the full weight of the machine (*Check machine gross weights in the Operating Spec Chart at the beginning of this Section*).
- Moved with a fork-lift truck using the fork-lift pockets in the base frame.

Truck Transport



DO NOT TRANSPORT THE MACHINE IN A HORIZONTAL POSITION DUE TO LEAKAGE OF BATTERY ACID FROM THE BATTERIES OR HYDRAULIC FLUID FROM THE HYDRAULIC RESERVOIR.

The machine may be winched onto a tilted roll-back truck bed (*see important note following*) which has been rolled back to ground level. Disengage the brakes and always winch (*pull*) from

the mast (*rear*) end of the machine, using the rear tie-down loop attached to the base frame.

NOTICE

DO NOT ATTEMPT TO DRIVE MACHINE ONTO, OFF OF, OR PUSH MACHINE ONTO A TILTED ROLL-BACK TRUCK BED.

THE MVL AND MSP MACHINES POWER MODULE COULD SUSTAIN SERIOUS DAMAGE WHEN THE UNIT IS PUSHED, OR TOWED AT SPEEDS GREATER THAN 2 MPH.

WHEN TOWING OR WINCHING, THE MACHINE'S BRAKES MUST BE DISENGAGED.

RE-ENGAGE THE BRAKES ONCE MACHINE IS IN PLACE WITH TRUCK BED LEVEL AND READY FOR TIE DOWN.

TIE DOWN LOOPS ARE PROVIDED ON BOTH ENDS OF THE BASE FRAME TO SECURE MACHINE TO BED OF TRANSPORT VEHICLE.

Machine Tie-Down

With machine in position to be tied down and brakes engaged, use the following guidelines for restraining the machine during transport.

NOTICE

USE OF EXCESSIVE FORCE WHEN SECURING MACHINE (DRIVE WHEEL LOAD), CAN CAUSE DAMAGE TO THE MACHINES DRIVE WHEEL COMPONENTS.

1. Secure machine with an adequate chain attached through the tie down loops located at the front and rear of machine. (See *Figure 3-6.*)
2. The chain should be securely tightened with a force of approximately 100 lb. applied two feet from the pivot handle.

Crane Hook Accessory (Option)

The crane hook accessory provides an attachment point for a lifting device to lift the machine. The lifting device must be capable of handling the gross weight of the machine, see the machine specifications Section 5 of this manual.

NOTICE

DO NOT ATTEMPT TO USE THE CRANE HOOK ACCESSORY AS AN ATTACH POINT TO LIFT ITEMS WITH THE MAST ASSEMBLY. THIS WILL RESULT IN DAMAGE TO THE MAST AND POSSIBLE MACHINE TIPPING.

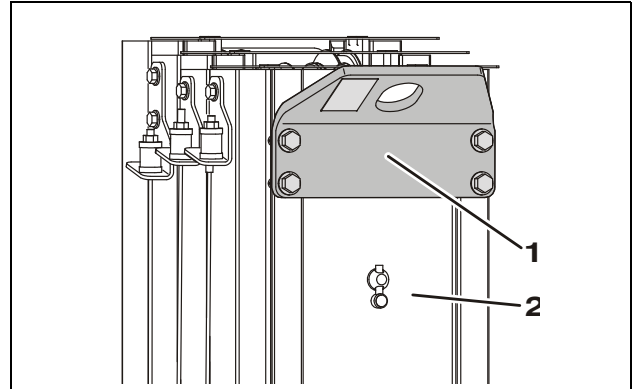

Figure 3-5. Crane Hook Accessory

1. Crane Hook Attachment

2. Back of Mast

Fork-Lift Truck Transport

All MVL and MSP Model Lifts are equipped with wide fork-lift pockets running the length of the base frame and also through the sides of the base. (See Figure 3-6.) This allows the machine to be either transported around a work area or lifted onto a higher level using a standard fork-lift truck.

NOTE: *Fork-lift trucks must be capable of handling the gross weight of the machine, see Section 5, GENERAL SPECIFICATIONS AND OPERATOR MAINTENANCE of this manual for machine specifications.*

SECTION 3 - MACHINE CONTROLS, INDICATORS AND OPERATION

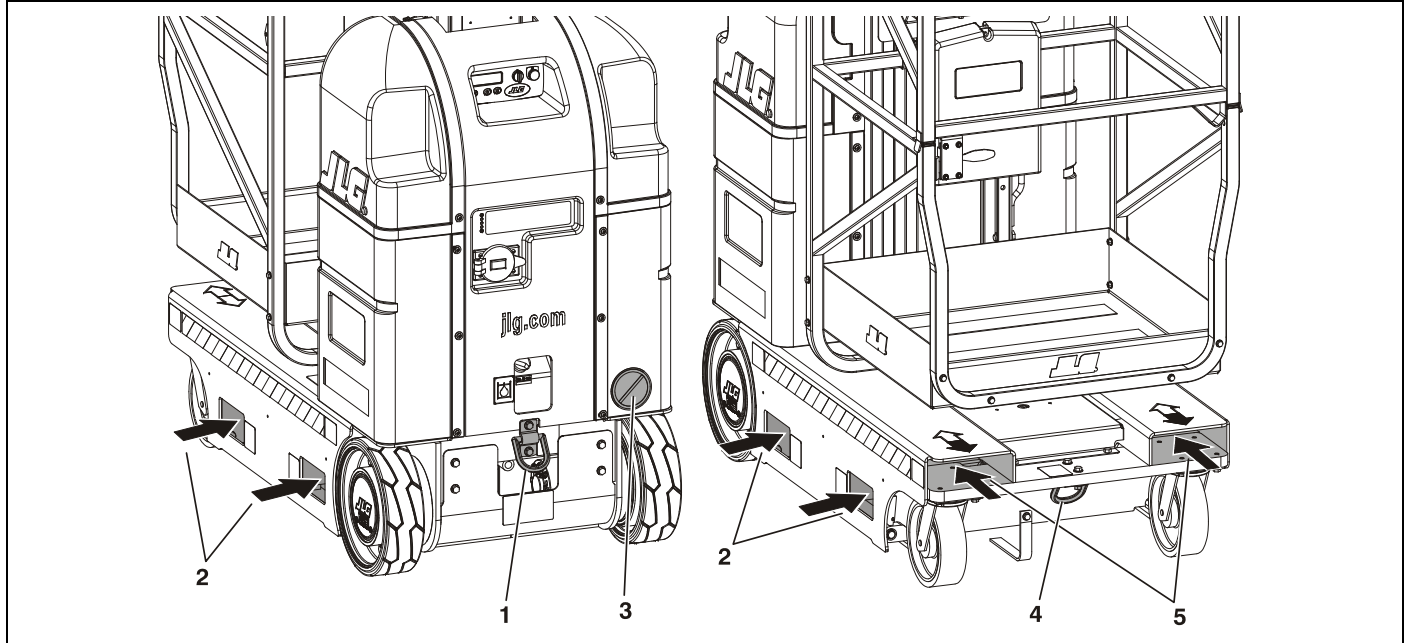

Figure 3-6. Forklift Truck Lifting Pockets and Machine Tie Down Loop Locations.

1. Rear Tie-Down Loop
2. Side Fork Lift Pockets
3. No Rear Fork Lifting Decal

4. Front Tie-Down Loop
5. Front Fork Lift Pockets

3.12 PROGRAMMABLE SECURITY LOCK (PSL™) (MVL/MSP - OPTION)

The optional Programmable Security Lock switch can be programmed with a four (4) digit operators code to allow only those persons with the code to power-up and operate the machine.

PSL™ Box and Ground Control Locations

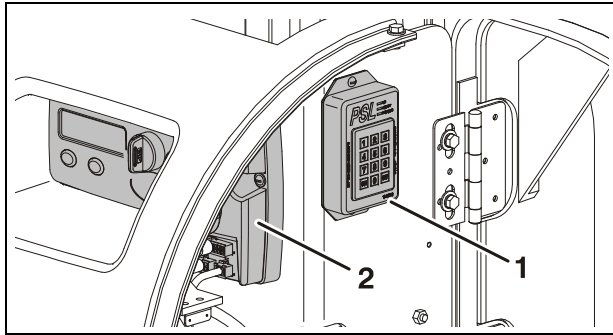

Figure 3-7. PSL™ Switch & Ground Control Station Locations - At Rear of Machine.

1. PSL Switch (Inside Right Cover) (a)
2. Ground Control Station

Note: (a) Machines with bolt on (fixed) covers, the PSL Switch is mounted on outside of right cover.



Figure 3-8. PSL™ Switch Controls & Indicators.

- | | |
|-----------------------|---------------|
| 1. ON (Green LED) | 4. Key Pad |
| 2. ACCEPT (Amber LED) | 5. OFF Switch |
| 3. PROGRAM (Red LED) | 6. ON Switch |

Machine Power Up using the PSL™

NOTE: *When entering code on the key pad, a short beep indicates a properly depressed key, a long beep indicates an error in depressing key. If an error occurs, you must restart the code entry process again.*

1. Enter the four digit code on the PSL key pad. The ACCEPT - AMBER LED indicator will be lit if the code is correct.
2. Press the keypad ON button. The ON - GREEN LED indicator will light and power will be supplied to the Ground Control Station.
3. At the ground control station, turn the main power selector switch from OFF to either Platform Control Mode or Ground Control Mode.
4. The machine will now operate normally.

Machine Power Down

1. At the Ground Control Station set the main power selector switch to the OFF position.
2. Press the OFF button on the PSL keypad. No LEDs on the PSL box will be lit.

Changing the Operator's Code

The PSL Operators Code can be changed by a supervisor should the need occur. A separate permanent Supervisor's Code matched to the serial number of the PSL box is included on a sheet in the PSL user manual supplied with the machine.

1. Enter the Supervisor's code on the key pad. The PROGRAM - RED LED will be lit if correct code is entered.

NOTE: *ON or OFF cannot be one of the four digits of the new Operator's code.*

2. Enter a new four (4) digit Operator's code on the keypad. The ACCEPT - AMBER LED will light up if the new Operator's code is accepted.
3. Press the OFF button on the keypad to activate the new Operator's code.

NOTE: *The new Operator's code will remain in the PSL even when power is removed from the equipment, or until the Supervisor changes the Operator's code.*

3.13 OBSTRUCTION SENSING SYSTEM - (MSP OPTION)

System Description

The Obstruction Sensing System (OSS) is designed to detect the presence of obstructions within a predetermined detection zone beneath the platform, when lowering the platform from an elevated position.

NOTE: *The OSS only operates normally when the Ground Control Module - Power Selector Switch is set to PLATFORM CONTROL MODE.*

When the Power Selector Switch is set to GROUND CONTROL MODE the OSS will detect an obstruction but will not stop platform downward movement or sound the horn. However, the OSS Control Module LED will flash if a sensor detects the presence of an object.

Operation

NOTE: *See Figure 3-10. for the location of the OSS Electronic module.*

When the machine is powered on a RED LED located on the OSS electronics module will illuminate. During platform lowering, if no obstructions have entered the detection zone beneath the platform, the platform will lower normally.

If an obstruction is detected within the detection zone beneath the platform, the platform will;

- Stop Lowering
- The RED LED on the electronics module will flash
- The horn will sound three short blasts

If an obstruction is detected, have the obstruction cleared by someone on the ground or carefully drive the lift until clear of the obstruction. Reset the OSS by pressing the horn button on the platform control once and continue machine operation. Should the OSS falsely detect an obstruction, the system can be overridden by pressing and holding the horn button while operating the platform lowering controls.



ALWAYS CHECK THE AREA UNDER THE PLATFORM IS CLEAR OF OBSTRUCTIONS BEFORE LOWERING THE PLATFORM.

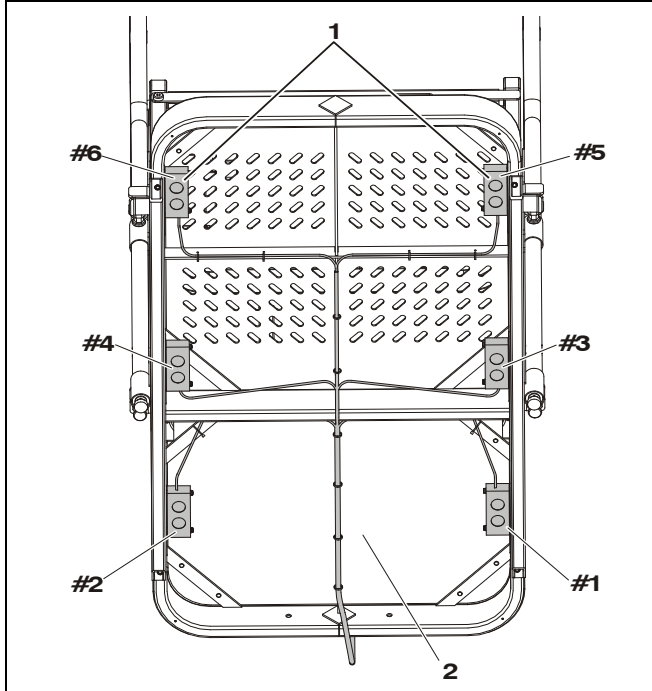

Figure 3-9. OSS Transducer Sensor Array Location.

1. Transducer Arrays #1 through #6
2. Underside of MSP Platform

OSS Pre-Start Inspection

(See Figure 3-10.)

From ground controls, raise platform approximately 5'-6'. The RED LED on the electronic module will be illuminated when power is applied. If an obstruction, such as a pad of paper is placed under any of the transducer sensor arrays, the RED LED will flash and remain flashing while the obstruction is present and stop flashing 3 seconds after the obstruction is removed. Check the operation of each transducer sensor array by placing an object individually under each sensor array (*within approximately 6"-12"*) and checking if the RED LED starts to "flash", and stops flashing 3 seconds after the obstruction is removed. Also, inspect the transducer arrays and electronic module for physical damage, loose wires, loose mounting hardware, etc.

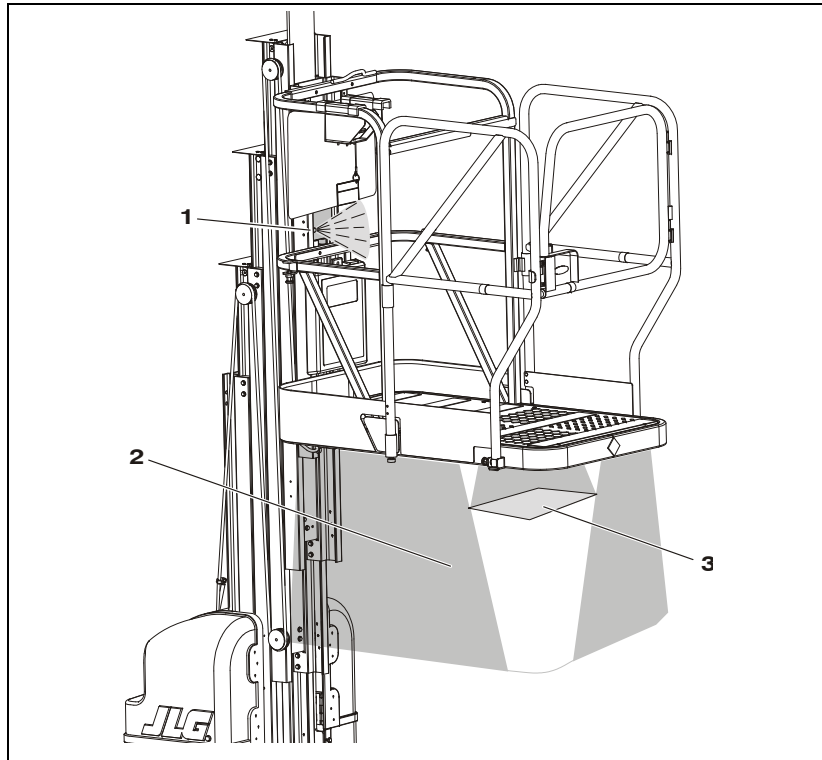

Figure 3-10. OSS - Pre-Start Inspection of Operation.

Pre-Start Inspection

1. Electronic Module LED Indicator (a)
2. Detection Zone
3. Place a pad of paper or similar size object, 6 to 12 in. (15 to 30cm) individually beneath each transducer to check detection.

NOTE: (a) The LED Indicator will flash when an object is detected at each sensor. Remove object and allow the LED to stop flashing before testing next sensor.

3.14 RUG CARRIER ACCESSORY (MSP - OPTION)

NOTE: *The Rug Carrier accessory is available only on the JLG MSP model and is not authorized for use with any other JLG lift. The Rug Carrier Accessory is intended for use in hanging and removal of rugs in hanging display racks only. Use for any other purpose is not authorized by JLG.*

General

The Rug Carrier Accessory consists of two pivoting arms mounted to the MSP platform left side rails. The pivoting arms are locked in the plane of the platform side rail when not in use (*the stowed position*). The arms are locked into position at approximately 90 degrees to the left side platform side rails when in use (*the carry position*). The pivoting arms' position can be changed by lifting each arm to release the lock, rotating the arm, and lowering each arm back into a locked position.

Pre-Start Inspection

Prior to use of the Rug Carrier accessory, check the following:

- Carrier arm mounting is secure to the platform railing, no missing or damaged fasteners.
- The arm lock pins are in place and working properly.

Hanging a Rug using the Rug Carrier Accessory Arms

The following is a description for use of the Rug Carrier accessory in hanging rugs on horizontal pivoting arm display racks.

1. Select the intended location in the display for mounting the rug. Open the display rack to provide adequate space for the MSP lift and rug.
2. With the Rug Carrier Accessory arms stowed, drive the MSP into position prior to loading the rug.
3. Swing and lock Rug Carrier Accessory arms into the carry position.
4. Load the rolled rug with the finished side facing the platform. As required, use an assistant to load the rug onto the Rug Carrier Accessory arms.
5. Make sure that the rug is centered over its length on the Rug Carrier Accessory.
6. Elevate the platform to the required height for mounting the rug onto the display arm.
7. Properly attach the rug to the display arm. Never climb onto the platform rails for any reason.
8. After adequately attaching the rug to the display arm, lower the platform, stow the Rug Carrier Accessory arms.

SECTION 3 - MACHINE CONTROLS, INDICATORS AND OPERATION

9. As required reposition and elevate the MSP to completely attach the rug.

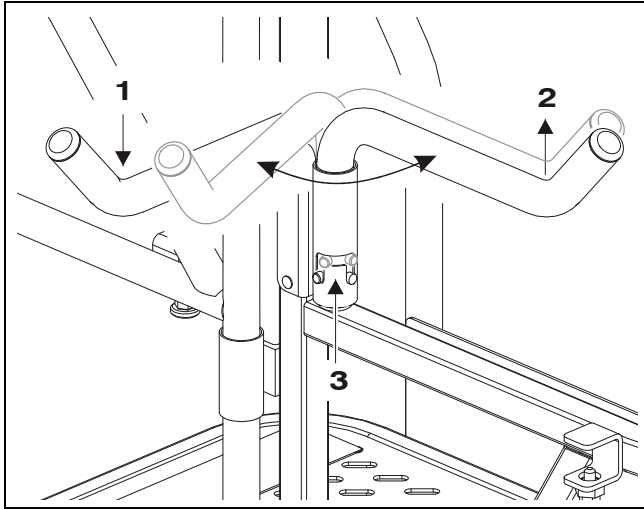

Positioning Rug Carrier Arms

1. Carry Position
2. Stowed Position
3. Lift Arm Up, Swing and Lock into Position

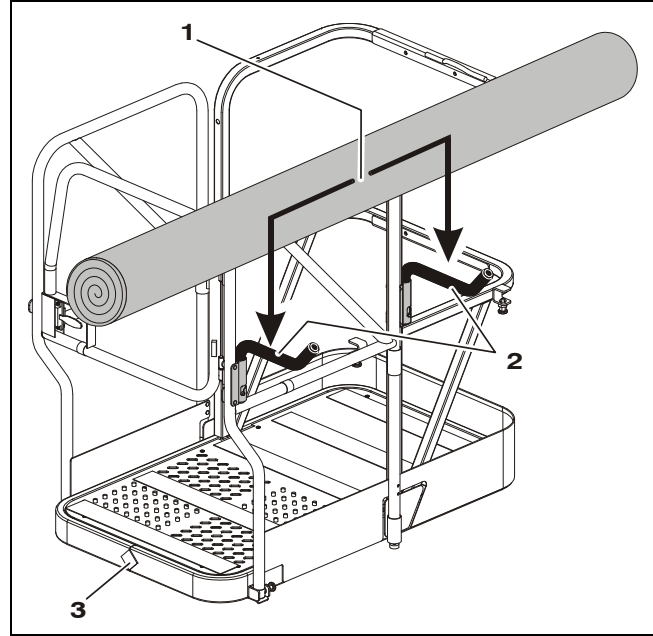

Positioning Carpet Roll On Rug Carrier

1. Center Carpet on Arms
2. Rest on Arms Here (a)
3. Platform Front

Note: (a) Maximum Capacity of Arms - 150 lb. (68kg)

Removing a Rug using Rug Carrier Accessory Arms

This section describes the use of the Rug Carrier accessory in removing a rug from a horizontal pivoting arm display rack.

1. Select the intended location in the display for removal of the rug. Open the display rack to provide adequate space for the MSP lift and rug.
2. With the Rug Carrier Accessory arms stowed, drive the MSP into position prior to loading the rug.
3. Swing and lock the Rug Carrier Accessory arms into the carry position.
4. Elevate the platform a few feet. Start to roll the rug onto the Rug Carrier Accessory arms.
5. Be certain the rug is centered over its length on the Rug Carrier Accessory.
6. While elevating to the required height for removing the rug from the display arm, continue to roll the rug until it is completely rolled up on the carrier arms.
7. Properly remove the rug from the display arm. Never climb onto the platform rails for any reason.
8. After adequately removing the rug from the display arm, lower the platform.

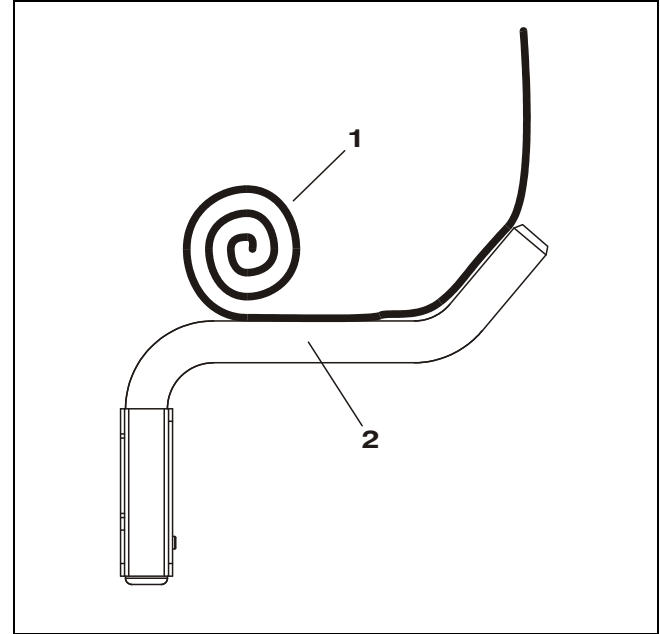

Removing Rug From Display Arm.

1. Roll Rug onto Rug Carrier while Elevating Platform
2. Rug Carrier in Carry Position

SECTION 3 - MACHINE CONTROLS, INDICATORS AND OPERATION

9. Remove the rug from the Rug Carrier Accessory. If required, use an assistant to unload the rug from the Rug Carrier Accessory Arms.
10. Replace the Rug Hanger Accessory arms to the stowed position for normal operation.



THE RUG CARRIER ACCESSORY ARMS MUST BE LOCKED IN THE STOWED POSITION WHEN NOT IN USE.

EXTREME CAUTION MUST BE EXERCISED AT ALL TIMES WHILE THE RUG CARRIER ACCESSORY IS IN USE (DRIVING, RAISING AND LOWERING) TO PREVENT OBSTACLES AND PERSONNEL FROM STRIKING THE LOAD.

WHEN DRIVING WITH A RUG WITHIN THE RUG CARRIER ACCESSORY, THE RUG MUST BE PROPERLY SECURED TO PREVENT INADVERTENT MOTION OR MOVEMENT OF THE RUG AND MUST NOT EXCEED THE RATED CAPACITY OF THE RUG CARRIER ACCESSORY.

NEVER OVERLOAD THE RUG CARRIER ACCESSORY. MAXIMUM CAPACITY OF THE RUG CARRIER ACCESSORY IS 150 LBS.

THE COMBINED WEIGHT OF PERSONNEL, MATERIALS, EQUIPMENT PLUS ANY LOAD ON THE RUG CARRIER ACCESSORY MUST NOT EXCEED THE MAXIMUM CAPACITY OF THE PLATFORM.

NEVER USE A RUG CARRIER ACCESSORY THAT HAS DAMAGE OR LOOSE

MOUNTINGS. IMMEDIATELY REPORT ANY DAMAGE TO APPROPRIATE PERSONNEL. DISCONTINUE USE OF THE RUG CARRIER ACCESSORY UNTIL ALL DISCREPANCIES HAVE BEEN CORRECTED.

3.15 STOCK-PICKER HANGER ACCESSORY

NOTE: *The stock-picker hanger accessory is available only on the JLG MSP model and is not authorized for use with any other JLG lift. This hanger accessory is intended for use in placing or retrieving stock items such as bicycles, ladders, etc., on racks or shelves above ground level. Use for any other purpose is not authorized by JLG.*

The hanger accessory is a pivoting arm mounted to the MSP platform rail. The hanger accessory can be mounted to either side of the platform individually, or two can be mounted, one on each side of the platform. Each individual hanger has a maximum load capacity of 100 lb. (45kg).

The hanger arm can be pivoted out of the way parallel with the platform side rails when not in use, (*the stowed position*). The hanger arm is pinned into position at 90 degrees to the platform side rails when in use, (*the carry position*).

Pre-Start Inspection

Prior to use of the hanger accessory, check the following;

- Hanger arm mounting is secure to the platform railing, no missing or damaged fasteners.
- The hanger arm lock pin is in place and secure.

CAUTION

THE COMBINED WEIGHT OF PERSONNEL, MATERIALS, EQUIPMENT PLUS ANY LOAD ON THE HANGER ARM ACCESSORY MUST NOT EXCEED THE MAXIMUM LOAD CAPACITY OF THE PLATFORM.

Loading and Transporting an Item using the Hanger Accessory

Use the following steps as a guide when loading and transporting an object with the hanger accessory arm.

1. Keep the hanger arm in the stowed position when not in use.
2. When ready to use, pull the lock pin from the stowed position hole and swing the hanger arm into the carry position. Place pin in the carry position hole locking the hanger arm in place.
3. Load the object onto the hanger arm and use the hanger arm strap to secure the object during transport.

NOTICE

MSP MACHINE'S EQUIPPED WITH THE OBSTRUCTION SENSING SYSTEM (OSS) OPTION – OBJECTS PLACED ON THE HANGER ACCESSORY AND EXTENDING BELOW THE BASE OF THE PLATFORM MAY CAUSE AN OSS DETECTION - SOUNDING THE HORN AND PREVENTING THE PLATFORM FROM LOWERING. IF NECESSARY, REPOSITION THE OBJECT OUT OF THE OSS DETECTION ZONE.

SECTION 3 - MACHINE CONTROLS, INDICATORS AND OPERATION

4. Be aware of clearance above, below, and around the object when driving and lifting or lowering the platform.

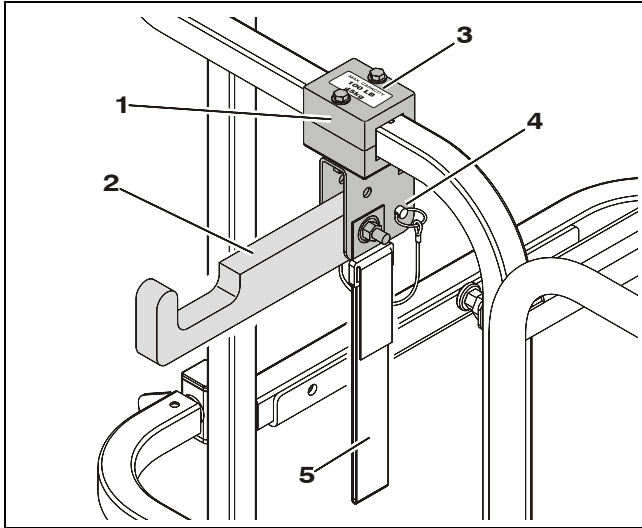

Stock Picker Hanger - Carry Position

- | | |
|--------------------------------|------------------------------|
| 1. Mounting Bracket | 4. Lock Pin (Carry Position) |
| 2. Hanger Arm (Carry Position) | 5. Hanger Arm Strap |
| 3. Capacity Decal (a) | |

Notes: (a) Maximum load capacity of hanger is 100 lb. (45kg).

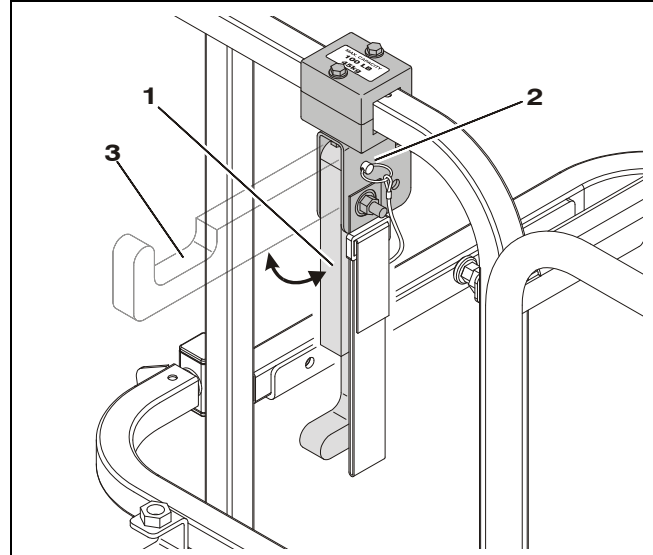

Stock Picker Hanger - Stowed Position

- | | |
|---------------------------------|--------------------------------|
| 1. Hanger Arm (Stowed Position) | 3. Hanger Arm (Carry Position) |
| 2. Lock Pin (Stowed Position) | |

SECTION 3 - MACHINE CONTROLS, INDICATORS AND OPERATION

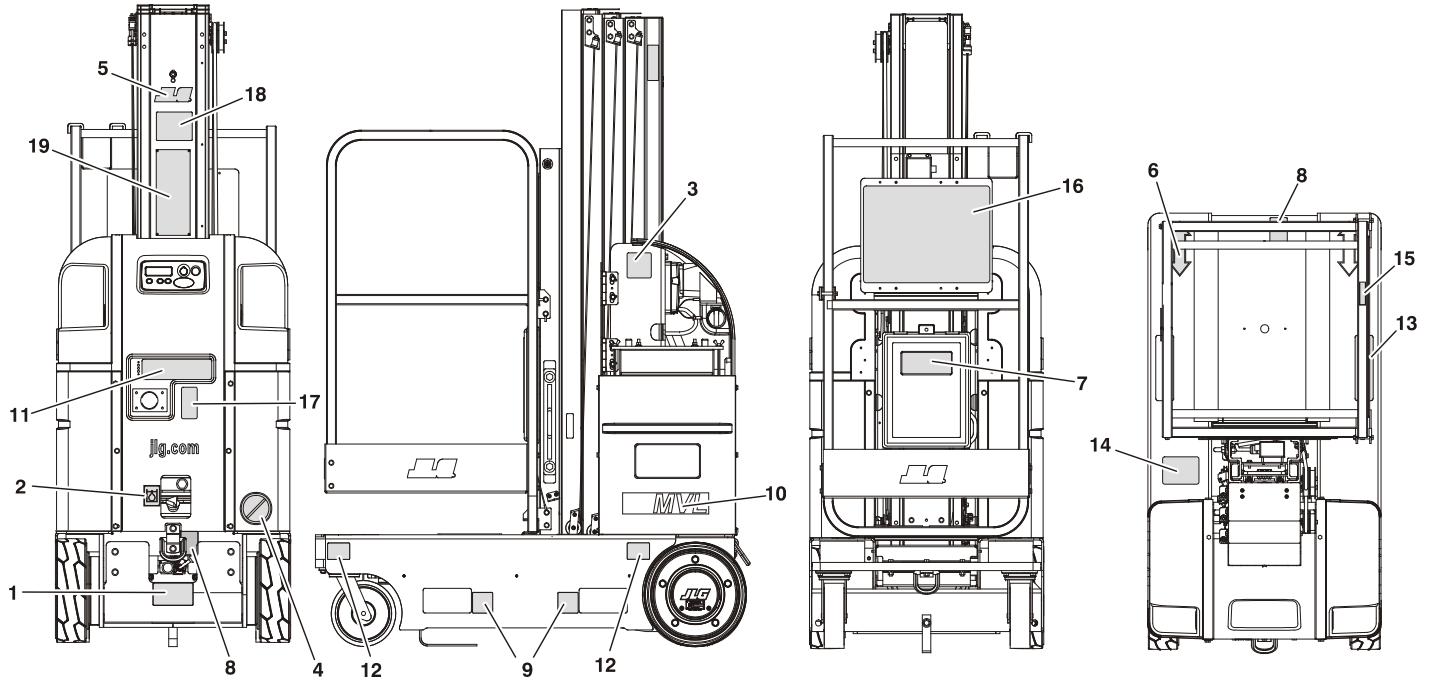

Figure 3-11. MVL Series Decal Installation Chart - (See Table 3-4 for Installation)

SECTION 3 - MACHINE CONTROLS, INDICATORS AND OPERATION

Table 3-4. MVL Series Decal Installation Chart.

	ANSI	ANSI (LAT)	ANSI (BRZ)	ANSI (JPN)	ANSI (CHI)	CSA (FRE)	CE (ENG/AUS)	CE (GER)	CE (FRE)	CE (SPA)	CE (ITA)	CE (DUT)	CE (SWE)
1	1705016	1705016	1705016	—	1705016	1705016	1705016	1705016	1705016	1705016	1705016	1705016	1705016
2	1701504	1701504	1701504	—	1701504	1701504	1701504	1701504	1701504	1701504	1701504	1701504	1701504
3	1702631	1702631	1702631	—	1702631	1702631	1702631	1702631	1702631	1702631	1702631	1702631	1702631
4	1703072	1703072	1703072	—	1703072	1703072	1703072	1703072	1703072	1703072	1703072	1703072	1703072
5	1703681	1703681	1703681	—	1703681	1703681	1703681	1703681	1703681	1703681	1703681	1703681	1703681
6	1703687	1703687	1703687	—	1703687	1703687	1703687	1703687	1703687	1703687	1703687	1703687	1703687
7	1701509	1701509	1701509	—	1701509	1701509	1701509	1701509	1701509	1701509	1701509	1701509	1701509
8	1703814	1703814	1703814	—	1703814	1703814	1703814	1703814	1703814	1703814	1703814	1703814	1703814
9	1703817	1703817	1703817	—	1703817	1703817	1703817	1703817	1703817	1703817	1703817	1703817	1703817
10	15MVL - 1706744 20MVL - 1706746	15MVL - 1706744 20MVL - 1706746	15MVL - 1706744 20MVL - 1706746	—	15MVL - 1706744 20MVL - 1706746	15MVL - 1706744 20MVL - 1706746	15MVL - 1706744 20MVL - 1706746	15MVL - 1706744 20MVL - 1706746	15MVL - 1706744 20MVL - 1706746	15MVL - 1706744 20MVL - 1706746	15MVL - 1706744 20MVL - 1706746	15MVL - 1706744 20MVL - 1706746	15MVL - 1706744 20MVL - 1706746
11	1705834	1705834	1705834	—	1705834	1705834	1705834	1705834	1705834	1705834	1705834	1705834	1705834
12	1705059	1705059	1705059	—	1705059	1705059	1705059	1705059	1705059	1705059	1705059	1705059	1705059
13	1703786	1704032	1704024	—	1704081	1001162896	1705099	1705099	1705099	1705099	1705099	1705099	1705099
14	1700584	1700584	1700584	—	1700584	1700584	1700584	1700584	1700584	1700584	1700584	1700584	1700584

SECTION 3 - MACHINE CONTROLS, INDICATORS AND OPERATION

Table 3-4. MVL Series Decal Installation Chart.

	ANSI	ANSI (LAT)	ANSI (BRZ)	ANSI (JPN)	ANSI (CHI)	CSA (FRE)	CE (ENG/ (AUS)	CE (GER)	CE (FRE)	CE (SPA)	CE (ITA)	CE (DUT)	CE (SWE)
15	1703684	1703685	1703686	—	1703751	1705959	1703684	1703718	1703719	1703685	1703721	1703722	1705100
16	15MVL - 1001117179 20MVL - 1001117185	15MVL - 1001117182 20MVL - 1001117188	15MVL - 1001117183 20MVL - 1001117187	—	15MVL - 1001117184 20MVL - 1001117189	15MVL - 1001162888 20MVL - 1001162895	15MVL -1001117181 20MVL - 1705960						
17	1703785	1704031	1704023	—	1704079	1001162897	1703785	1704071	1704042	1704031	1704063	1704055	1705102
18	1703779	—	—	—	—	—	—	—	—	—	—	—	—
19	3252797	1702797	1702797	—	1702797	1001095340	3252798	3252798	3252798	3252798	3252798	3252798	3252798

SECTION 3 - MACHINE CONTROLS, INDICATORS AND OPERATION

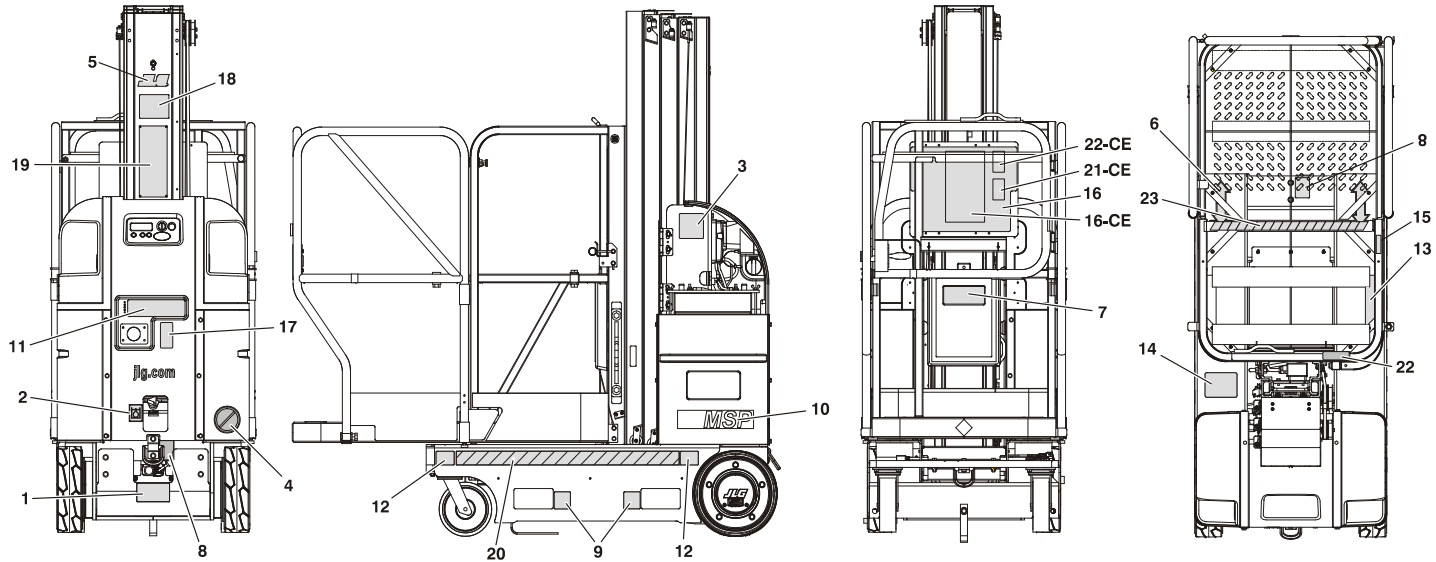

Figure 3-12. MSP Decal Installation Chart - (See Table 3-5. for Installation)

SECTION 3 - MACHINE CONTROLS, INDICATORS AND OPERATION

Table 3-5. MSP Decal Installation Chart.

	ANSI	ANSI (LAT)	ANSI (BRZ)	ANSI (JPN)	ANSI (CHI)	CSA (FRE)	CE (ENG/ AUS)	CE (GER)	CE (FRE)	CE (SPA)	CE (ITA)	CE (DUT)	CE (SWE)	CE (FIN)
1	1705016	1705016	1705016	—	1705016	1705016	1705016	1705016	1705016	1705016	1705016	1705016	1705016	1705016
2	1701504	1701504	1701504	—	1701504	1701504	1701504	1701504	1701504	1701504	1701504	1701504	1701504	1701504
3	1702631	1702631	1702631	—	1702631	1702631	1702631	1702631	1702631	1702631	1702631	1702631	1702631	1702631
4	1703072	1703072	1703072	—	1703072	1703072	1703072	1703072	1703072	1703072	1703072	1703072	1703072	1703072
5	1703681	1703681	1703681	—	1703681	1703681	1703681	1703681	1703681	1703681	1703681	1703681	1703681	1703681
6	1703687	1703687	1703687	—	1703687	1703687	1703687	1703687	1703687	1703687	1703687	1703687	1703687	1703687
7	1703788	1703788	1703788	—	1703788	1703788	1703788	1703788	1703788	1703788	1703788	1703788	1703788	1703788
8	1703814	1703814	1703814	—	1703814	1703814	1703814	1703814	1703814	1703814	1703814	1703814	1703814	1703814
9	1703817	1703817	1703817	—	1703817	1703817	1703817	1703817	1703817	1703817	1703817	1703817	1703817	1703817
10	15MSP - 1706745 20MSP - 1706747	15MSP - 1706745 20MSP - 1706747	15MSP - 1706745 20MSP - 1706747	—	15MSP - 1706745 20MSP - 1706747	15MSP - 1706745 20MSP - 1706747	15MSP - 1706745 20MSP - 1706747	15MSP - 1706745 20MSP - 1706747	15MSP - 1706745 20MSP - 1706747	15MSP - 1706745 20MSP - 1706747	15MSP - 1706745 20MSP - 1706747	15MSP - 1706745 20MSP - 1706747	15MSP - 1706745 20MSP - 1706747	15MSP - 1706745 20MSP - 1706747
11	1705834	1705958	1705860	—	1705862	1705958	1705958	1705958	1705958	1705958	1705958	1705958	1705958	1705958
12	1705059	1705059	1705059	—	1705059	1705059	1705059	1705059	1705059	1705059	1705059	1705059	1705059	1705059
13	1703786	1704032	1704024	—	1704081	1001162896	1705099	1705099	1705099	1705099	1705099	1705099	1705099	1705099
14	1700584	1700584	1700584	—	1700584	1700584	1700584	1700584	1700584	1700584	1700584	1700584	1700584	1700584

SECTION 3 - MACHINE CONTROLS, INDICATORS AND OPERATION

Table 3-5. MSP Decal Installation Chart.

	ANSI	ANSI (LAT)	ANSI (BRZ)	ANSI (JPN)	ANSI (CHI)	CSA (FRE)	CE (ENG/ (AUS)	CE (GER)	CE (FRE)	CE (SPA)	CE (ITA)	CE (DUT)	CE (SWE)	CE (FIN)
15	1703684	1703685	1703686	—	1703751	1705959	1703684	1703718	1703719	1703685	1703721	1703722	1705101	1705100
16	15MVL - 1001117179 20MVL - 1001117185	15MVL - 1001117182 20MVL - 1001117188	15MVL - 1001117183 20MVL - 1001117187	—	15MVL - 1001117184 20MVL - 1001117189	15MVL - 1001162888 20MVL - 1001162895	15MVL - 1001117181 20MVL - 1705960							
17	1703785	1704031	1704023	—	1704079	1001162897	1703785	1704071	1704042	1704031	1704063	1704055	1705103	1705102
18	1703779	—	—	—	—	—	—	—	—	—	—	—	—	—
19	3252797	3252797	3252797	—	3252797	1001095340	3252798	3252798	3252798	3252798	3252798	3252798	3252798	3252798
20	4420051	4420051	4420051	—	4420051	4420051	4420051	4420051	4420051	4420051	4420051	4420051	4420051	4420051
21	—	—	—	—	—	1705966	1705966	1705966	1705966	1705966	1705966	1705966	1705966	1705966
22	1704366	1705141	1705142	—	1704910	1704804	1705965	1705965	1705965	1705965	1705965	1705965	1705965	1705965
23	1704469	1705153	1705154	—	1705155	1705156	1705964	1705964	1705964	1705964	1705964	1705964	1705964	1705964

SECTION 4. EMERGENCY PROCEDURES

4.1 GENERAL INFORMATION

This section explains the steps to be taken in case of an emergency situation during operation.

4.2 EMERGENCY OPERATION

Operator Unable to Control Machine

IF THE PLATFORM OPERATOR IS PINNED, TRAPPED OR UNABLE TO OPERATE OR CONTROL THE MACHINE:

1. Other personnel should operate the machine from ground controls only as required.
2. Only qualified personnel in the platform may use the platform controls. **DO NOT CONTINUE OPERATION IF CONTROLS DO NOT FUNCTION PROPERLY.**
3. Rescue equipment can be used to remove the platform occupant. Cranes and forklifts can be used to stabilize motion of the machine.

Platform Caught Overhead

If the platform becomes jammed or snagged in overhead structures or equipment, rescue the platform occupant prior to freeing the machine.

4.3 INCIDENT NOTIFICATION

JLG Industries, Inc. must be notified immediately of any incident involving a JLG product. Even if no injury or property damage is evident, the factory should be contacted by telephone and provided with all necessary details.

USA: 877-JLG-SAFE (554-7233)

Outside USA: 717-485-5161

E-mail: productsafety@jlg.com

Failure to notify the manufacturer of an incident involving a JLG Industries product within 48 hours of such an occurrence may void any warranty consideration on that particular machine.

NOTICE

FOLLOWING ANY ACCIDENT, THOROUGHLY INSPECT THE MACHINE AND TEST ALL FUNCTIONS FIRST FROM THE GROUND CONTROL STATION, THEN FROM THE PLATFORM CONTROL CONSOLE. DO NOT ELEVATE PLATFORM UNTIL YOU ARE SURE THAT ALL DAMAGE HAS BEEN REPAIRED, IF REQUIRED, AND THAT ALL CONTROLS ARE OPERATING CORRECTLY.

SECTION 5. GENERAL SPECIFICATIONS AND OPERATOR MAINTENANCE

5.1 INTRODUCTION

This section of the manual provides additional necessary information to the operator for proper operation and maintenance of this machine.

The maintenance portion of this section is intended as information to assist the machine operator to perform daily maintenance tasks only, and does not replace the more thorough Preventive Maintenance and Inspection Schedule included in the Service and Maintenance Manual.

Other Publications Available Specific to this Machine:

Service and Maintenance Manual

GLOBAL..... 3121231

Illustrated Parts Manual

GLOBAL..... 3121232

5.2 GENERAL SPECIFICATIONS

Machine Specifications

SPECIFICATION	15MVL	20MVL	15MSP	20MSP
Gross Machine Weight (<i>Platform Empty</i>):	2,235 lb. (1,014 kg)	2,235 lb. (1,014 kg)	2,280 lb. (1,034 kg)	2,280 lb. (1,034 kg)
Machine Height (<i>Platform Stowed</i>):	78 in. (198cm)			
Tilt Indicator Setting:	1.5°			
Maximum Travel Grade (Gradeability): (Platform STOWED ONLY)	20%			
Maximum Travel Grade (Side Slope): (Platform STOWED ONLY)	5°			
Maximum Drive Speeds (<i>Operator Variable</i>):	0.5 - 3.4 mph (0.8 - 5.5 kph)			
Machine Base - Overall : (<i>Width x Length</i>)	29.25 in.- W x 52 in.- L (74cm) x (132cm)			
Maximum Wind Speed:	28 mph (12.5 m/s) - ANSI/CSA 0 mph (0kph) - CE/AUSTRALIA			
Maximum Horizontal Manual Side Force: (<i>Platform fully extended with Maximum load</i>)	45 Pound Force (200 Newtons)			

SECTION 5 - GENERAL SPECIFICATIONS AND OPERATOR MAINTENANCE

SPECIFICATION	15MVL	20MVL	15MSP	20MSP
Maximum Hydraulic System Pressure: <i>(Recommended initial setting)</i>	2600 PSI (180 Bars)	1800 PSI (124 Bars)	2600PSI (180 Bars)	2800 PSI (193 Bars)
Hydraulic System Capacity:	5 qts. U.S. (4.7L)			
Hydraulic Reservoir Capacity:	1 Gallon (3.78 L)			

SECTION 5 - GENERAL SPECIFICATIONS AND OPERATOR MAINTENANCE

Machine Wheel Loads and PSI - Per Wheel

Table 5-1. 15MVL/MSP - Machine Maximum Wheel Loads (Lb.) and (PSI) - Per Wheel.

Platform Type (Loaded to Max. Capacity)	15MVL				15MSP			
	Average Maximum				Average Maximum			
	Wheel Load Per Wheel		(PSI) Per Wheel		Wheel Load Per Wheel		(PSI) Per Wheel	
	Rear	Front	Rear	Front	Rear	Front	Rear	Front
22x25 SB	865 lb. (393 kg)	490 lb. (223 kg)	138 PSI (9.8 kg/cm ²)	252 PSI (17.8 kg/cm ²)				
28x26 GW	845 lb. (384 kg)	550 lb. (250 kg)	128 PSI (9 kg/cm ²)	265 PSI (18.7 kg/cm ²)				
26x50 GW	860 lb. (390 kg)	515 lb. (234 kg)	115 PSI (8.0 kg/cm ²)	321 PSI (22.6 kg/cm ²)	860 lb. (390 kg)	515 lb. (234 kg)	115 PSI (8.0 kg/cm ²)	321 PSI (22.6 kg/cm ²)
28x48 SP					755 lb. (343 kg)	615 lb. (279 kg)	117 PSI (8.3 kg/cm ²)	306 PSI (21.6 kg/cm ²)
w/Folding Tray					810 lb. (368 kg)	565 lb. (257 kg)	125 PSI (8.8 kg/cm ²)	313 PSI (22 kg/cm ²)

NOTE: Platform Types: SB - with Sliding Bar Gate GW - with Gull Wing Gate SP - Stock Picker Platform

SECTION 5 - GENERAL SPECIFICATIONS AND OPERATOR MAINTENANCE

Table 5-2. 20MVL/MSP - Machine Maximum Wheel Loads (Lb.) and (PSI) - Per Wheel.

Platform Type (Loaded to Max. Capacity)	20MVL				20MSP			
	Average Maximum				Average Maximum			
	Wheel Load Per Wheel (Lb.)		(PSI) Per Wheel		Wheel Load Per Wheel (Lb.)		(PSI) Per Wheel	
	Rear	Front	Rear	Front	Rear	Front	Rear	Front
22 x 25 SB	855 lb. (388 kg)	450 lb. (206 kg)	132 PSI (9.3 kg/cm ²)	250 PSI (17.6 kg/cm ²)				
28 x 26 GW	835 lb. (379 kg)	460 lb. (209 kg)	121 PSI (8.6 kg/cm ²)	261 PSI (18.4 kg/cm ²)				
26 x 50 GW	850 lb. (386 kg)	480 lb. (218 kg)	131 PSI (9.3 kg/cm ²)	277 PSI (19.5 kg/cm ²)	850 lb. (386 kg)	480 lb. (218 kg)	131 PSI (9.3 kg/cm ²)	259 PSI (18.3 kg/cm ²)
28 x 48 SP					815 lb. (370 kg)	560 lb. (255 kg)	120 PSI (8.5 kg/cm ²)	320 PSI (22.5 kg/cm ²)
w/Folding Tray					810 lb. (368 kg)	565 lb. (257 kg)	125 PSI (8.8 kg/cm ²)	313 PSI (22 kg/cm ²)

NOTE: Platform Types: SB - with Sliding Bar Gate GW - with Gull Wing Gate SP - Stock Picker Platform

SECTION 5 - GENERAL SPECIFICATIONS AND OPERATOR MAINTENANCE

Electrical Specifications

SPECIFICATION		15MVL	20MVL	15MSP	20MSP
System Voltage:		24 Volts DC			
Battery Specifications:	Battery Type:	AGM (VRLA) (Sealed)			
	Voltage (DC):	12 Volts DC - 2 Battery System 6 Volts DC - 4 Battery System			
	Amp Hour (AH) Rating:	100 Amp Hr. @ 20 Hr. Rate - 12V - 2 Battery System 220 Amp Hr. @ 20 Hr. Rate - 6V - 4 Battery System			
Battery Charger (DC Models)	Input (AC):	120/230 VAC RMS - 45/65 Hz - Voltage Selectable 12AMPS RMS@108 VAC			
	Output (DC):	24 Volts DC Nominal -33.6 VDC Maximum 25 Amp - Max. DC Output Current			

SECTION 5 - GENERAL SPECIFICATIONS AND OPERATOR MAINTENANCE

Platform Data

SPECIFICATION	15MVL	20MVL	15MSP	20MSP
Occupants: <i>(Persons allowed in Platform)</i>	1			
Maximum Work Load (Capacity): Gull Wing or Front Slide Bar Entry: Stockpicker: Extendible:	500 lb. (230 kg)	350 lb. (160 kg)	—	—
	—	—	500 lb. (230 kg)	400 lb. (180 kg)
	500 lb. (230 kg)	350 lb. (160 kg)	500 lb. (230 kg)	350 lb. (160 kg)
Platform w/Folding Material Tray:	<i>(See Table 3-3 on page 3-26)</i>			
Platform Height - Mast Fully Extended - <i>(Ground to Platform Floor):</i>	15 ft. 2 in. (4.69 m)	19 ft. 1 in. (5.80 m)	15 ft. 1 in. ⁽¹⁾ (4.66 m)	19 ft. 6 in. (5.96 m)
Platform Cycle Performance: <i>(in seconds) (w/max. rated load)</i>	Lift Up:	20 sec.	22.5 sec.	20 sec.
	Lift Down:	15 - 21 sec.	21 - 26 sec.	15 - 21 sec.

NOTE: (1) Standard unless equipped with optional 14 ft. Limiter circuit.

Machine Component Weights

SPECIFICATION	15MVL	20MVL	15MSP	20MSP
Platform Weight : Front Slide Bar Entry Platform: <i>(Quick-Change Platforms)</i>	55 lb. (25 kg)			
Gull Wing Platform:	70 lb. (32 kg)			
Battery: <i>(per battery)</i>	71-75 lb. (34 kg) - 12 Volt - 2 Battery System 66 lb. (30 kg) - 6 Volt - 4 Battery System			

Serial Number Locations

For machine identification, a serial number plate is affixed to the machine. The plate is located on the back of the mast, just above the mast support bracket.

5.3 OPERATOR MAINTENANCE

Battery

The OEM batteries are AGM sealed (VRLA) type so the electrolyte level cannot be serviced, however the battery terminals should be checked periodically for corrosion and tightness. The batteries are located under the top rear hood covers on each side of the Ground Control Station.

Tires and Wheels

Tire Wear and Damage

Inspect tires periodically for wear or damage. Tires with worn edges or distorted profiles require replacement. Tires with significant damage in the tread area or side wall, require immediate evaluation before replacing the machine into service.

Wheel and Tire Replacement

Replacement wheels must have the same diameter and profile as the original. Replacement tires must be the same size and rating as the tire being replaced.

Wheel Installation

It is extremely important to apply and maintain proper wheel mounting torque.

WARNING

WHEEL LUG NUTS MUST BE INSTALLED AND MAINTAINED AT THE PROPER TORQUE TO PREVENT LOOSE WHEELS, BROKEN LUG NUTS, AND POSSIBLE SEPARATION OF WHEEL FROM THE AXLE. BE SURE TO USE ONLY THE LUG NUTS MATCHED TO THE CONE ANGLE OF THE WHEEL.

SECTION 5 - GENERAL SPECIFICATIONS AND OPERATOR MAINTENANCE

Tighten the lug nuts to the proper torque to prevent wheels from coming loose. Use a torque wrench to tighten the fasteners. If you do not have a torque wrench, tighten the fasteners with a lug wrench, then immediately have a service garage or dealer tighten the lug nuts to the proper torque. Over-tightening will result in breaking the lug nuts or permanently deforming the mounting holes in the wheels. The proper procedure for attaching wheels is as follows:

1. Start all lug nuts by hand to prevent cross threading. DO NOT use a lubricant on threads or nuts.
2. Tighten lug nuts in the following sequence.

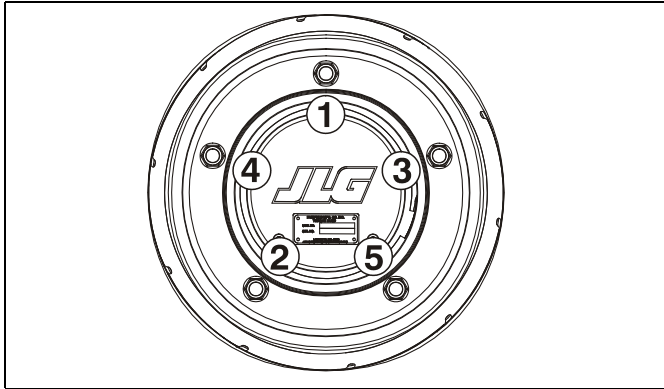

Figure 5-1. Wheel Lug Nut Tightening Sequence

3. The tightening of the lug nuts should be done in stages. Following the recommended sequence, tighten lug nuts per wheel torque.

Table 5-3. Wheel Torque Chart

TORQUE SEQUENCE		
1st Stage	2nd Stage	3rd Stage
20-30 ft lbs (28 - 42 Nm)	65-80 ft lbs (91 - 112 Nm)	105 -120 ft lbs (142 - 163 Nm)

4. Wheel lug nuts should be torqued after the first 50 hours of operation and after each wheel removal. Check torque every 3 months or 150 hours of operation.

SECTION 5 - GENERAL SPECIFICATIONS AND OPERATOR MAINTENANCE

Lubrication

Hydraulic Oil (HO)

HYDRAULIC SYSTEM OPERATING TEMPERATURE RANGE	SAE VISCOSITYGRADE
+0° F to +180° F (-18° C to -83° C)	10W
+0° F to +210° F (-18° C to +99° C)	10W-20, 10W-30
+50° F to +210° F (+10° C to +99° C)	20W-20

Hydraulic oils must have anti-wear qualities at least to API Service Classification GL-3, and sufficient chemical stability for mobile hydraulic system service. JLG Industries, recommends Mobilfluid 424 hydraulic oil, which has an SAE viscosity of 10W-30 and a viscosity index of 152.

For cold weather applications, i.e. when temperatures remain consistently below +20°F (-7°C) JLG recommends using Mobil DTE 13 hydraulic oil.

Aside from JLG recommendations, it is not advisable to mix oils of different brands or types, as they may not contain the same required additives or be of comparable viscosities. If use of hydraulic oil other than Mobilfluid 424 is desired, contact JLG Industries for proper recommendations.

Table 5-4. - Lubrication Specifications

KEY	SPECIFICATIONS
MPG -	Multipurpose Grease having a minimum dripping point of 350° F. Excellent water resistance and adhesive qualities, and being of extreme pressure type. (Timken OK 40 pounds minimum.)
EPGL -	Extreme Pressure Gear Lube (oil) meeting API service classification GL-5 or MIL-Spec MIL-L-2105.
HO -	Hydraulic Oil. ISO-Vg grade 32, 46.
CL -	Chain Lube. Use a good quality chain lubricant

NOTE: Refer to Lubrication Chart, Table 5-5 for specific lubrication locations on machine.

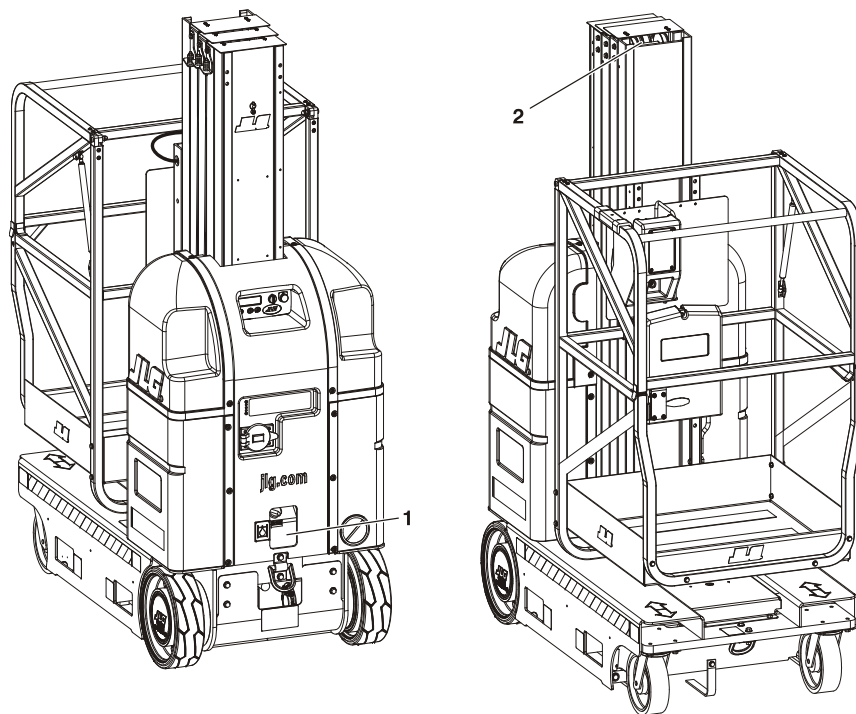

Figure 5-2. Location of Lubrication Points (See Table 5-5)

SECTION 5 - GENERAL SPECIFICATIONS AND OPERATOR MAINTENANCE

Table 5-5. Lubrication Intervals for Various Components

ITEM	COMPONENT	NO/TYPE (a) LUBE POINTS	LUBE/METHOD	INTERVAL (b)				COMMENTS
				3 MONTHS	6 MONTHS	1 YEAR	2 YEARS	
1	Hydraulic Oil	Fill To Line on Reservoir 5 Qt. Reservoir	HO - Check Hyd. Oil Level HO - Change Hyd. Oil				✓	Check fluid level every day. (c) Change hydraulic oil every 2 years.
2	Mast Chains	2 - Per Mast Section	CL - Brush or Spray		✓			Inspect, lubricate if dry or rusting.
Key to Lubricants: MPG - Multipurpose Grease HO - Hydraulic Oil - ISO-Vg grade 32, 46. CL - Chain Lube. Use a good quality chain lubricant								
Notes: (a) Be certain to lubricate like items on each side of the machine. (b) Recommended lubricating intervals are based on normal use. If machine is subjected to severe operating conditions, such as a high number of cycles, location, corrosive/dirty environment, etc., user must adjust lubricating requirements accordingly. (c) Prior to checking hydraulic oil level, operate machine through one complete cycle of lift function (full up and down). Failure to do so will result in incorrect oil level reading on the hydraulic reservoir.								

5.4 GROUND CONTROL STATION - PROGRAMMING

General

The MVLMS/MSP machine Ground Control Station allows on-board programming of various component and control function personality settings.

Programming may be required under circumstances such as:

- Optional equipment has been added to the machine in the field and a function must be enabled before operation.
- Customizing the machine to fit a specific application, such as changing the LCD display language.

Programming Levels

There is one (1) **password protected** programming level available to the Operator:

- **Level-3:** Operator's Settings -
Level-3 Password: 33271

Operator Programming Mode

In the Operator Level Programming Mode the following items are shown on the main menu (See Table 5-6 for Setting Range and Default Factory Setting):

- **Tilt Sensor**
Allows viewing current tilt sensor individual X and Y direction degree reading.
- **Program**
Allows programming of the items shown in Table 5-6 on page 5-16, the following is a brief explanation of each programming item.

NOTE: *There are two production modules available at this time, one for North/South American and European languages, and one for Asian languages. All programmable items between these modules are identical with the exception of language selection.*

- **Back To Main** - When selected, will return to main level menu.
- **Set Language** - Selects the language that text on the LCD screen will be displayed.
- **Set Sleep Time** - Allows setting the length of time the machine will remain powered up without control input before powering itself down.

SECTION 5 - GENERAL SPECIFICATIONS AND OPERATOR MAINTENANCE

- **Set Polarity of Keypad Code** - Turns on or off the Programmable Security Lock switch circuit, if equipped.
- **Enable Detection of Horn Open Circuit** - Enables horn electrical circuit to be turned on (YES) or off (NO) if machine is equipped with a horn.
- **Enable Detection of Beacon Open Circuit** - Enables mast/base beacon strobe electrical circuits to be turned on (YES) or off (NO) if machine is equipped with either or both beacon strobes.
- **Forward Alarm Disable** - When turned on (YES) will disable the alarm when driving forward.
- **OSS Diagnostics** - When turned on (YES) will cause the controller LCD to continuously display the Obstruction Sensing System (OSS) Diagnostics until turned back off (NO).....the machine will function normally, but only the OSS Diagnostics screen will display until this setting is reset to the off (NO) position.

SECTION 5 - GENERAL SPECIFICATIONS AND OPERATOR MAINTENANCE

Table 5-6. Ground Control Module Setting Range and Default Factory Settings.

Level-3: Operator Programmable Settings		On LCD Display: YES = ✓ HIGH = ↑ NO = ✗ LOW = ↓	
LEVEL	PROGRAMMABLE ITEM	FACTORY PRESET	SETTING RANGE
3	Back to Main	—	Return to Main Menu
3	Set Language <i>NOTE: There are two production modules available at this time, one for North/South American and European Languages, and one for Asian Languages.</i>	1	1 - English 6 - Italian 2 - German 7 - Swedish 3 - Dutch 8 - Brazilian Portuguese 4 - French 9 - Finnish 5 - Spanish
		2	1 - English 3 - Japanese 2 - Chinese
3	Set Sleep Time	5 MINS	0 - 60 MINS
3	Set Polarity of the Keypad Code	LOW	HIGH/LOW
3	Enable Detection of Horn Open Circuit	NO (a)	YES/NO
3	Enable Detection of Beacon Open Circuit	NO (a)	YES/NO
3	Forward Alarm Disable	NO	YES/NO
3	OSS Diagnostics	NO	YES/NO

Notes:(a) MSP Models this feature is standard equipment and preset to YES at factory.

Activating Programming Mode

NOTE: If machine does not power up, check that both the Ground Control Station - Emergency Stop Button, and the Platform Control Console - Emergency Stop Button, are in the RESET position.

Also if machine is equipped with the (PSL) Programmable Security Lock option, see Section 3.5 of this Operators Manual for additional machine power-up steps.

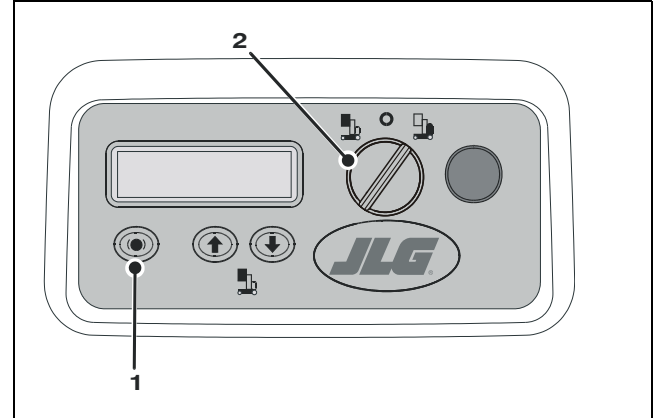

1. With machine power OFF, press and hold the Brake Release Button (1) on the Ground Control Station.
2. While holding the Brake Release Button in, power machine up by turning the Main Power Selector Switch (2), to either the Ground Control or Platform Control Mode.
3. Release the Brake Release Button (1) after machine is powered up. The LCD display should now display five zeros, one with a box around. Continue to next step Entering Password.

SECTION 5 - GENERAL SPECIFICATIONS AND OPERATOR MAINTENANCE

Entering Password

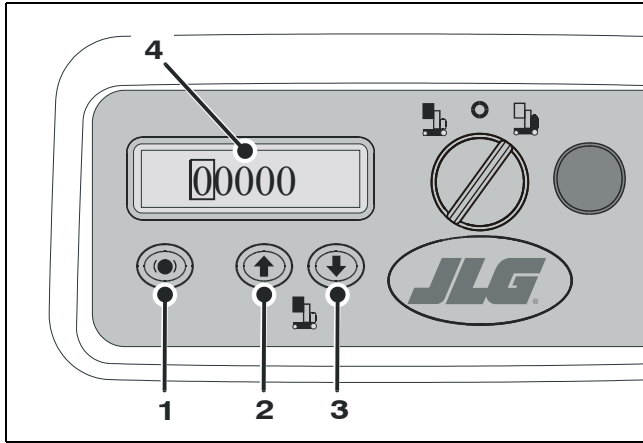

1. The Brake Release button (1) moves the box from left to right to select which digit to change.
2. Platform UP button (2) increases the numerical digit.
3. Platform DOWN button (3) decreases the numerical digit.
4. Change all five digits (4) to match password level, then press the Brake Release button (1) again.

Programming Mode Selection

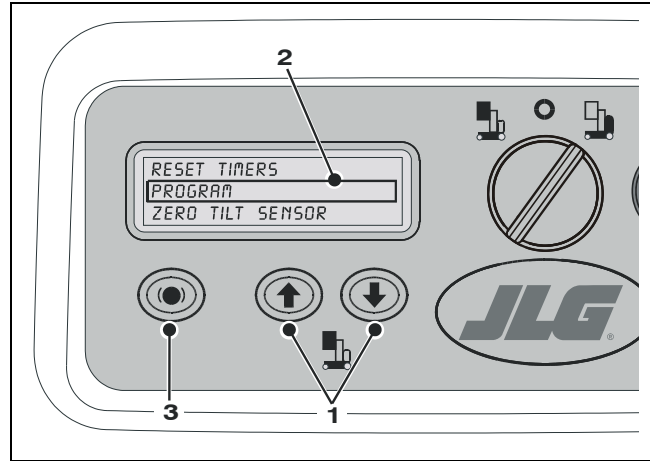

1. Use Platform UP/DOWN buttons (1) to move the selection box (2) up or down to select item to program.
2. Press the Brake Release button (3) to enter selected mode then move on to Selecting Programmable Item to adjust.

Selecting Programmable Item to Adjust

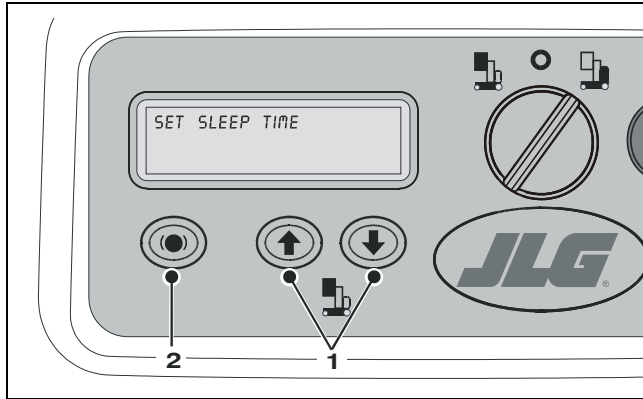

1. Use the Platform UP/DOWN buttons (1) to scroll through the list of programmable items available to your programming level.
2. Once a programmable item to be adjusted is selected, press the Brake Release button (2) to enter that settings' adjustment mode.

Adjusting Programmable Setting

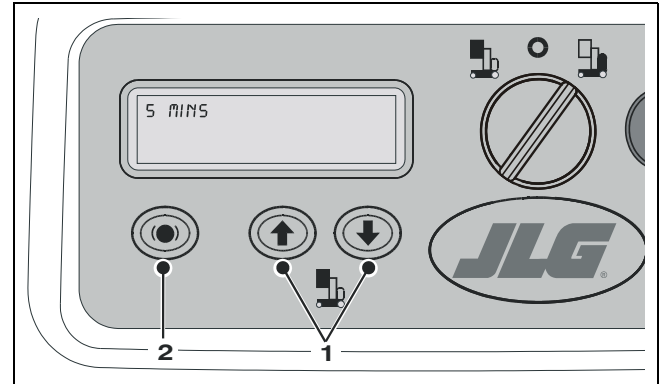

1. Adjust the programmable setting using the Platform UP/DOWN buttons (1), see Table 5-6 for range of settings for that item.
2. Once parameter is set for the programmable item, press the Brake Release button (2), this will enter the parameter and return you to the Programmable Settings Menu.

TO EXIT Programming Mode after adjusting programmable settings, power machine down with either the Main Power Selector Switch or Emergency Stop Button.

5.5 DRIVE MOTOR BRUSH WEAR - WARNING INDICATION

The machines drive motors include brush wear sensors that activate a warning indicating the drive motor brushes will require replacement soon. This warning protects the drive motors from damage due to extreme brush wear.

When the brush wear warning is activated the Ground Control Station LCD screen will indicate a fault code of 6, also the hour-meter is set to countdown 25 hours of (DRIVE) operation remaining.

The Platform Control LEDs will indicate this warning with 8 flashing LEDs and an intermittent beep.

NOTE: *Only the drive function when used will affect the hour meter count down once the warning has been activated. The machine will operate normally until the last 10 seconds of the 25 hour countdown.*

During the last 10 seconds of the 25 hour (DRIVE) countdown the machine will only drive in creep/turtle drive mode and platform lift up will be disabled. At this point cycling power on/off will only repeat the final 10 second mode cycle.

The machine will not operate normally until the drive motor brushes are replaced (*repositioning the brush warning sensors*), and the Ground Control Station is programmed to reset the Brush Wear - Warning Timer per the Service and Maintenance Manual.

5.6 SUPPLEMENTAL INFORMATION

The following information is provided in accordance with the requirements of the European Machinery Directive 2006/42/EC and is only applicable to CE machines.

For electric powered machines, the equivalent continuous A-Weighted sound pressure level at the work platform is less than 70dB(A).

For combustion engine powered machines, guaranteed Sound Power Level (LWA) per European Directive 2000/ 14/EC (Noise Emission in the Environment by Equipment for Use Outdoors) based on test methods in accordance with Annex III, Part B, Method 1 and 0 of the directive, is 109 dB.

The vibration total value to which the hand-arm system is subjected does not exceed 2,5 m/s². The highest root mean square value of weighted acceleration to which the whole body is subjected does not exceed 0,5 m/s².



An Oshkosh Corporation Company

TRANSFER OF OWNERSHIP

To Product Owner:

If you now own but ARE NOT the original purchaser of the product covered by this manual, we would like to know who you are. For the purpose of receiving safety-related bulletins, it is very important to keep JLG Industries, Inc. updated with the current ownership of all JLG products. JLG maintains owner information for each JLG product and uses this information in cases where owner notification is necessary.

Please use this form to provide JLG with updated information with regard to the current ownership of JLG products. Please return completed form to the JLG Product Safety & Reliability Department via facsimile or mail to address as specified below.

Thank You,
Product Safety & Reliability Department
JLG Industries, Inc.
13224 Fountainhead Plaza
Hagerstown, MD 21742
USA
Telephone: +1-717-485-6591
Fax: +1-301-745-3713

NOTE: Leased or rented units should not be included on this form.

Mfg. Model: _____

Serial Number: _____

Previous Owner: _____

Address: _____

Country: _____ Telephone: (____) _____

Date of Transfer: _____

Current Owner: _____

Address: _____

Country: _____ Telephone: (____) _____

Who in your organization should we notify?

Name: _____

Title: _____

CALIFORNIA PROPOSITION 65
BATTERY WARNING

**Battery posts, terminals
and related accessories
contain lead and lead
compounds, chemicals
known to the State of
California to cause cancer
and reproductive harm.**

**Batteries also contain other
harmful chemicals known
to the State of California.**

**WASH HANDS
AFTER HANDLING!**



An Oshkosh Corporation Company

JLG Industries, Inc.
1 JLG Drive
McCconnellsburg PA. 17233-9533
USA

(717) 485-5161 (Corporate)
 (800) 544-5438 (Service)
 (717) 485-6417
www.jlg.com

JLG Worldwide Locations

JLG Industries
358 Park Road
Regents Park
NSW 2143
Sydney 2143
Australia
 +6 (12) 87186300
 +6 (12) 65813058
Email: techservicesauc@jlg.com

JLG Ground Support Oude
Bunders 1034
Breitwaterstraat 12A
3630 Maasmechelen
Belgium
 +32 (0) 89 84 82 26
Email: emeaservice@jlg.com

JLG Latino Americana LTDA
Rua Antonia Martins Luiz, 580
Distrito Industrial Joao Narezzi
Indaiatuba-SP 13347-404
Brasil
 +55 (19) 3936 7664 (Parts)
 +55(19)3936 9049 (Service)
Email: comercialpecas@jlg.com
Email: servicios@jlg.com

Oshkosh-JLG (Tianjin) Equipment
Technology LTD
Shanghai Branch
No 465 Xiao Nan Road
Feng Xian District
Shanghai 201204
China
 +86 (21) 800 819 0050

JLG Industries Dubai
Jafza View
PO Box 262728, LB 19
20th Floor, Office 05
Jebel Ali, Dubai
 +971 (0) 4 884 1131
 +971 (0) 4 884 7683
Email: emeaservice@jlg.com

JLG France SAS
Z.I. Guillaume Mon Amy
30204 Fauillet
47400 Tonniens
France
 +33 (0) 553 84 85 86
 +33 (0) 553 84 85 74
Email: pieces@jlg.com

JLG Deutschland GmbH
Max Planck Str. 21
2721 Ritterhude - Ihlpohl
Germany
 +49 (0) 421 69350-0
 +49 (0) 421 69350-45
Email:german-parts@jlg.com

JLG Equipment Services Ltd.
Rm 1107 Landmark North
39 Lung Sum Avenue
Sheung Shui N. T.
Hong Kong
 +(852) 2639 5783
 +(852) 2639 5797

JLG Industries (Italia) S.R.L.
Via Po. 22
20010 Pregnana Milanese (MI)
Italy
 +39 (0) 2 9359 5210
 +39 (0) 2 9359 5211
Email: ricambi@jlg.com

JLG EMEA B.V.
Polaris Avenue 63
2132 JH Hoofddorp
The Netherlands
 +31 (0) 23 565 5665
Email: emeaservice@jlg.com

JLG NZ Access Equipment & Services
28 Fisher Crescent
Mt Wellington 1060
Auckland, New Zealand
 +6 (12) 87186300
 +6 (12) 65813058
Email:techservicesaus@jlg.com

JLG Industries
Vahutinskoe shosse 24b.
Khimki
Moscow Region 141400
Russia Federation
 +7 (499) 922 06 99
 +7 (499) 922 06 99

Oshkosh-JLG Singapore Technology
Equipment Pte Ltd.
35 Tuas Avenue 2
Jurong Industrial Estate
Singapore 639454
 +65 6591 9030
 +65 6591 9045
Email: SEA@jlg.com

JLG Iberica S.L.
Trapadella, 2
Pol. Ind. Castellbisbal Sur
08755 Castellbisbal Barcelona
Spain
 +34 (0) 93 772 47 00
 +34 (0) 93 771 1762
Email:parts_iberica@jlg.com

JLG Industries (UK) Ltd.
Bentley House
Bentley Avenue
Middleton, Greater Manchester
M24 2GP
United Kingdom
 +44 (0) 161 654 1000
 +44 (0) 161 654 1003
Email: ukparts@jlg.com

JLG Sverige AB
Enkopingsvagen 150
176 27 Jarfalla
Sweden
 +46 (0) 8 506 595 00
 +46 (0) 8 506 595 27
Email: nordicsupport@jlg.com